

## XPORTEXPRESS Fairing

Thank you for choosing the XPORTEXPRESS Fairing. This accessory will help to reduce wind noise and increase fuel efficiency. The XPORTEXPRESS Fairing is made to mount easily, quickly and exclusively to the XPORTEXPRESS Roof Rack System.

### Please read and understand the following roof rack guidelines:

**! WARNING:** Pay particular attention to the vehicle manufacturer's roof weight bearing recommendation. For security and safety, you must refer to the vehicle manufacturer's guidelines for the permissible weight for a roof top carrier.

- Use only racks or accessories that are compatible with the XPORTEXPRESS Roof Rack System, and only for vehicles listed in the XPORTEXPRESS Fit Guide.
- Do not carry more than 165 lbs on the XPORTEXPRESS Crossbars. Use of the XPORTEXPRESS rack does not increase gutter or roof strength. Misuse can result in damage to vehicle, gear and rack. Other vehicles can be damaged and people can be hurt or killed in accidents caused by a rack falling from a vehicle. **Caution: It is the consumer's responsibility to ensure safe and proper installation.**
- Read and follow the instructions carefully.
- Drive safely. Do not exceed the posted speed limit while using the rack.
- Please note that vehicles handle differently when a roof rack is fitted, and especially when loaded. Vehicles may corner and brake differently, and may be more vulnerable to side winds.
- It is essential that all connections and accessory attachments be tightened correctly and checked at regular intervals.
- For reasons of safety and fuel efficiency, removal of the rack is recommended when not in use.
- The rack may limit the operation of some sun roofs.
- Clean with mild soap and water only. Some chemicals can damage nylon and rubber parts.

For questions about your XPORTEXPRESS installation call Performance Technical Support at 1-800-553-8324. M-F, 9-6 EST

## Parts Diagram *Fig. 1*

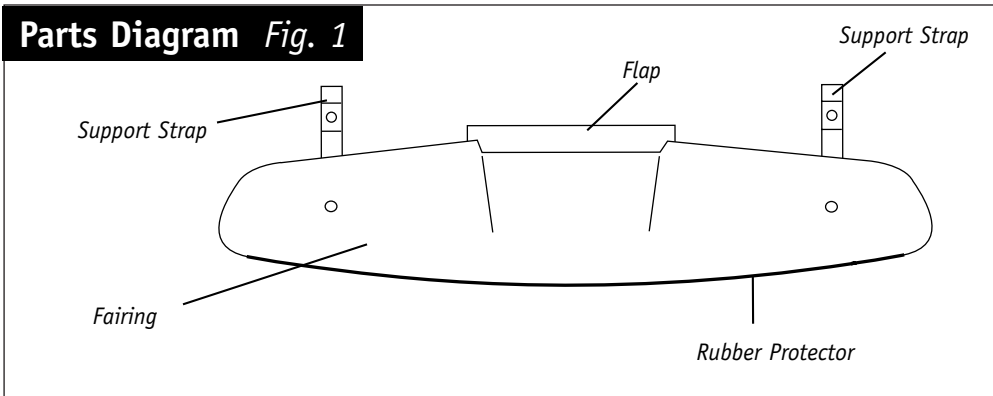

### Assembly & Installation:

If you are mounting this carrier to a rack with the Foot Kit already open, proceed to step 5.

1. Push the lock cover up to expose the keyhole (see figure 2).
  2. Unlock the mechanism with your key. Pull the Black Ratchet Lever back without clicking the ratchet mechanism (see figure 3).
  3. Push forward on the Yellow Release Lever that is now exposed, while applying light pressure to the Black Ratchet Lever. The hook attached to your vehicle will release (see figure 3).
  4. Push the Black Ratchet Lever closed, creating slack (no tension) on the steel strap. The Black Ratchet Lever can then be opened fully (see figure 4).
  5. Remove the rubber trim strips from the top of the front Foot Assembly and Crossbar.
- Note:** If you already have accessories mounted to your rack, it may be necessary to temporarily remove them to make room for the Steel Supports of the Fairing. In most cases the Steel Supports will be mounted inboard on the Crossbar relative to the bicycle carriers.
6. Insert bolt into Support Clip.
  7. Slide one of the Support Clips into the open channel (with the threaded screw pointing up) of the front Foot Assembly/Crossbar. Slide it approximately 3/4 of the way along the channel towards the other Foot.
  8. Slide the other Support Clip a few inches into the same channel.
  9. While holding the Fairing in place (forward of the front Crossbar), align the Support Strap nearest to you with the appropriate Support Clip/Screw. Thread on a Nut just enough to hold one side in place (1 or 2 turns). (See figure 5.)
  10. Tuck the middle flap of the Fairing under the front Crossbar (see figure 6).
  11. Align the other Support Strap and Support Clip/Screw, and thread the second Nut a few turns onto the Support Post.
  12. Center the Fairing left to right, then tighten both Nuts until the nylon portion of each Nut is threaded on to the Support Post (see figure 7).

**Note:** It is important that the front edge of the Fairing does not obstruct the driver's field of vision.

13. Install the Plastic Caps onto the Nuts.

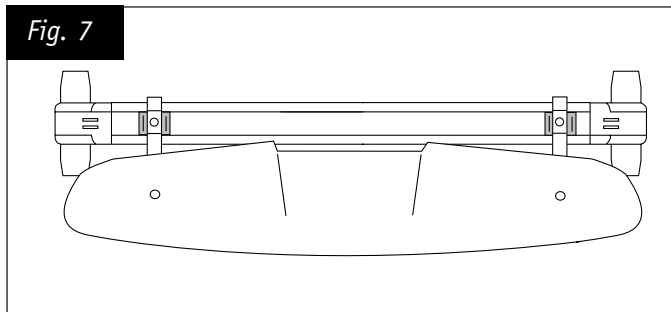
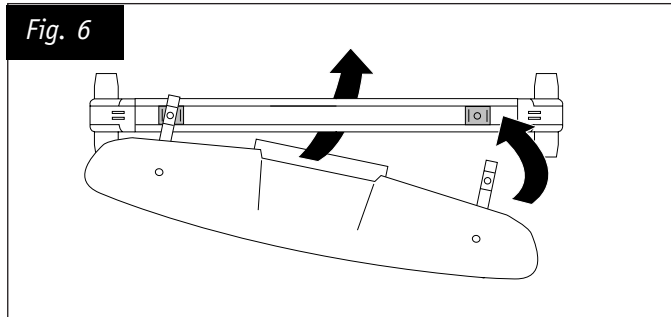
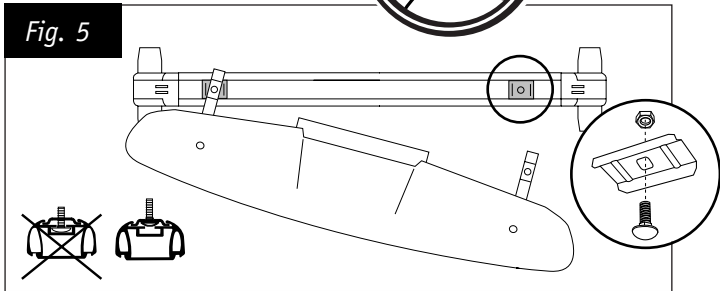
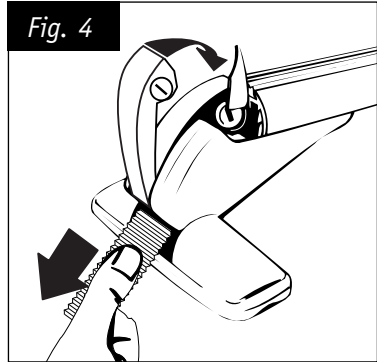
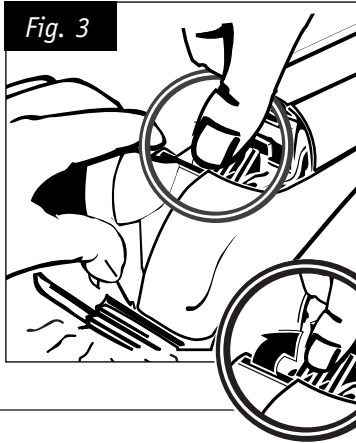
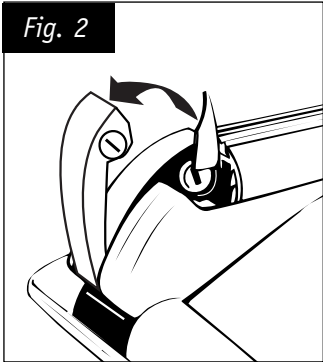

14. Replace any other accessories that were removed during the Fairing installation.
15. Replace Rubber Trim pieces as needed, by cutting sections to fit in the open channel.
16. Close the Black Ratchet Lever. If the Hook Kit was loosened during the installation, retighten by slowly pulling back on the Black Ratchet Lever (while holding the Hook in position) and then close the Black Ratchet Lever.

**Caution:** *Do not pull the Black Lever past vertical or use excessive force to tighten. The XPORT XPRESS lever mechanism provides considerable mechanical advantage and can damage your vehicle if overtightened.*

*For questions regarding installation call Performance Technical Support*  
**M-F, 9-6 EST**  
**1-800-553-8324**



**Performance Inc.**

One Performance Way  
Chapel Hill, NC 27514  
Made in Canada

***performancebike.com***