

XPORT XPress Fork Mount Carrier

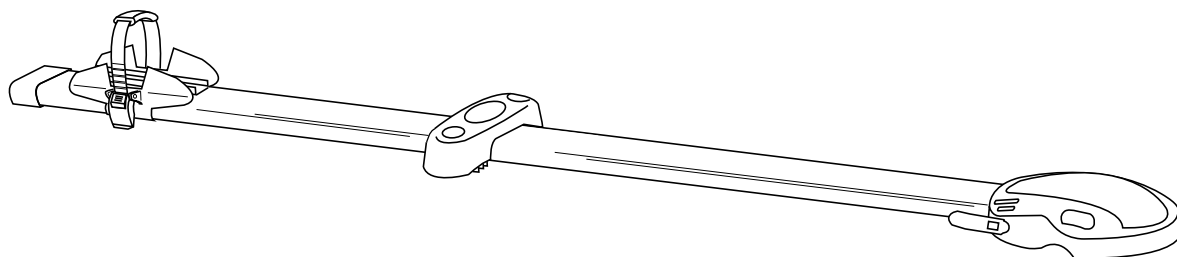

Thank you for choosing the XPORT XPress Fork Mount Carrier. This carrier is designed to hold both ATB and road bicycles. The XPORT XPress Fork Mount Carrier is made to mount easily, quickly and exclusively to the XPORT XPress Roof Rack System.

Please read and understand the following roof rack guidelines:

⚠ WARNING: Pay particular attention to the vehicle manufacturer's roof weight bearing recommendation. For security and safety, you must refer to the vehicle manufacturer's guidelines for the permissible weight for a roof top carrier.

- Use only racks or accessories that are compatible with the XPORT XPress Roof Rack System, and only for vehicles listed in the XPORT XPress Fit Guide.
- Do not carry more than 165 lbs on the XPORT XPress Crossbars. Use of the XPORT XPress rack does not increase gutter or roof strength. Misuse can result in damage to vehicle, gear and rack. Other vehicles can be damaged and people can be hurt or killed in accidents caused by a rack falling from a vehicle. **Caution: It is the consumer's responsibility to ensure safe and proper installation.**
- Read and follow the instructions carefully.
- Drive safely. Do not exceed the posted speed limit while using the rack.
- Please note that vehicles handle differently when a roof rack is fitted, and especially when loaded. Vehicles may corner and brake differently, and may be more vulnerable to side winds.
- It is essential that all connections and accessory attachments be tightened correctly and checked at regular intervals.
- For reasons of safety and fuel efficiency, removal of the rack is recommended when not in use.
- The rack may limit the operation of some sun roofs.
- Clean with mild soap and water only. Some chemicals can damage nylon and rubber parts.

For questions about your XPORT XPress installation call Performance Technical Support at 1-800-553-8324, M-F, 9-6 EST.

Important limitations of your bicycle carrier:

The distance between the XPORT XPress crossbars must be at least 40cm.

DO NOT USE THE XPORT XPRESS FORK MOUNT CARRIER IF THE DISTANCE IS LESS THAN THIS.

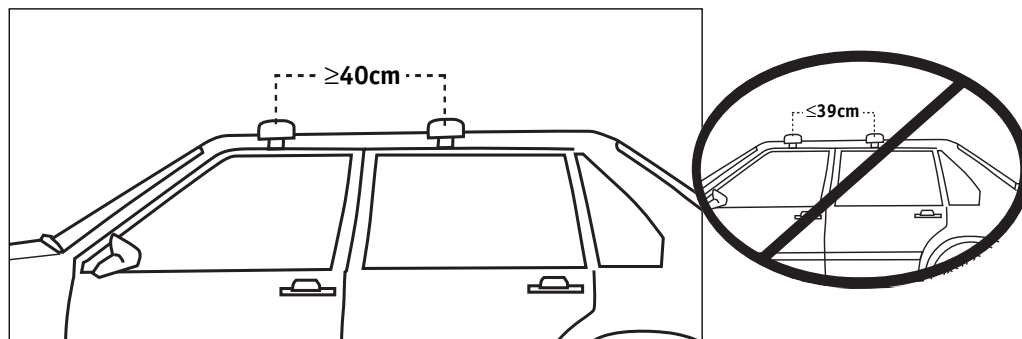

- The Fork Block Assembly will secure bicycle forks with an inside spacing of 4" (100mm) only.
- In accordance with the DIN and ISO, no part of the bicycle(s) may protrude beyond the gutters or, in the case of vehicles without gutters, beyond the outer edge of the roof.
- Bicycles with disc wheels or any other wheels that do not allow the use of a Tie-down Strap must not be carried on any XPORT XPress bicycle carrier. Due to high wind resistance, we do not suggest transporting bikes with these items attached: baby seats, panniers, wheel covers, full bike covers.

These instructions assume that you already have an XPORT XPress Roof Rack (Hook Kit, Foot Pack, and Crossbars) mounted to your vehicle. To properly install the roof rack, please see the instructions included with the XPORT XPress Roof Rack Components.

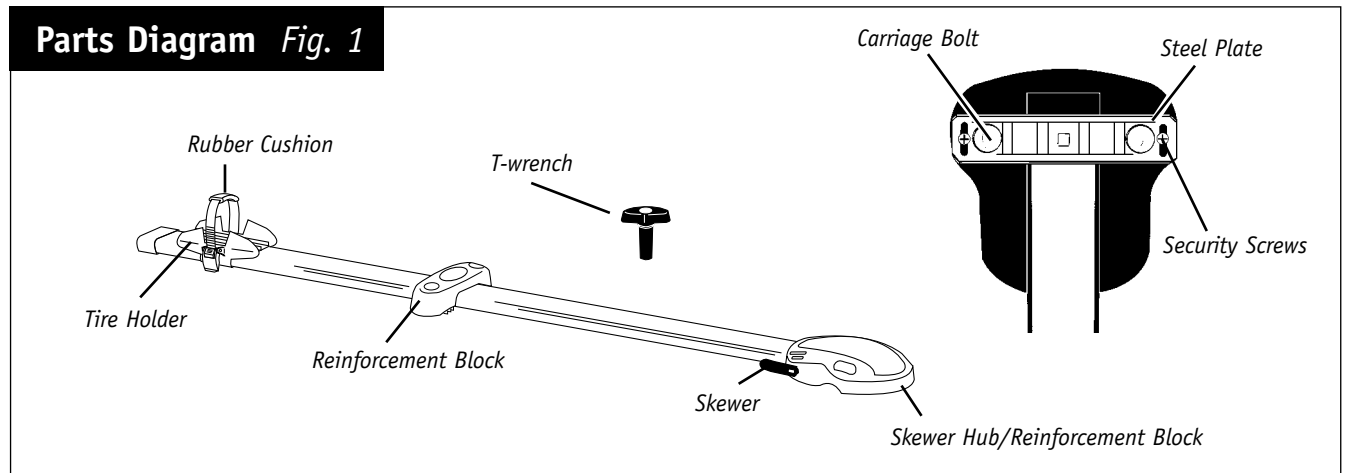

Assembly & Installation

If you are mounting this carrier to a rack with the Foot Kit already open, proceed to step 5.

1. Push the lock cover up to expose the keyhole (see figure 2).
2. Unlock the mechanism with your key. Pull the Black Ratchet Lever back without clicking the ratchet mechanism (see figure 3).
3. Push forward on the Yellow Release Lever that is now exposed, while applying light pressure to the Black Ratchet Lever. The hook attached to your vehicle will release (see figure 3).
4. Push the Black Ratchet Lever closed, creating slack (no tension) on the steel strap. The Black Lever can then be opened fully (see figure 4).
5. Remove the Rubber Trim strips from the top of the Foot Assemblies and/or Crossbars (depending on where the Fork Mount Carrier is to be mounted on the rack).
6. Loosen (but do not remove) the bolts from the front and rear Reinforcement Blocks. Slide the steel plates below the Reinforcement Blocks into the channels at the top of the Foot Assemblies (see figure 5).
7. Once the carrier is placed in the desired position, use the "T-wrench" included with the Carrier to tighten the Reinforcement Block bolts. Tighten both nuts on each reinforcement block until the nylon portion of the nut is threaded on to the bolt (see figure 6).
8. Replace the Rubber Trim pieces as needed, by cutting sections to fit in the open channel.
9. Close the Black Ratchet Lever. If the Hook Kit was loosened during the installation, retighten by slowly pulling back on the Black Ratchet Lever (while holding the Hook in position).

Caution: Do not pull the Black Lever past vertical or use excessive force to tighten. The XPORT XPress lever mechanism provides considerable mechanical advantage and can damage your vehicle if overtightened.

Fig. 2

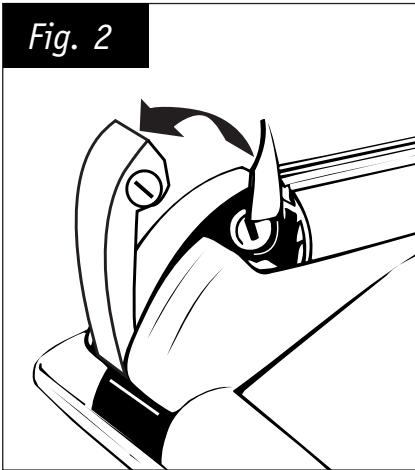

Fig. 3

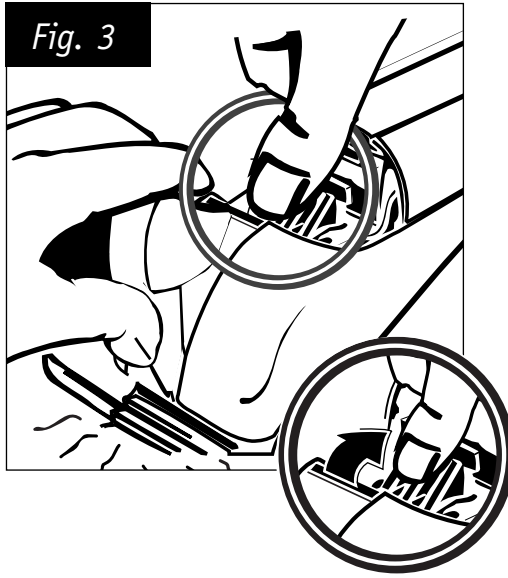

Fig. 4

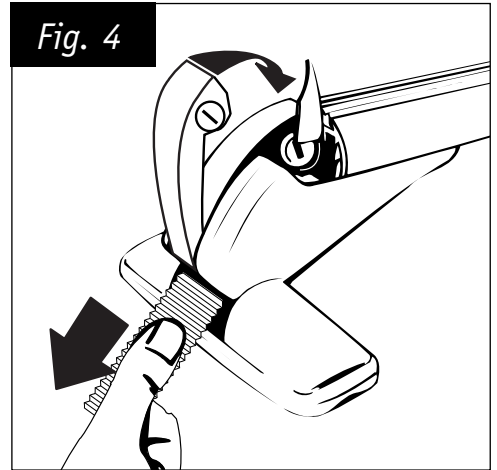

Fig. 5

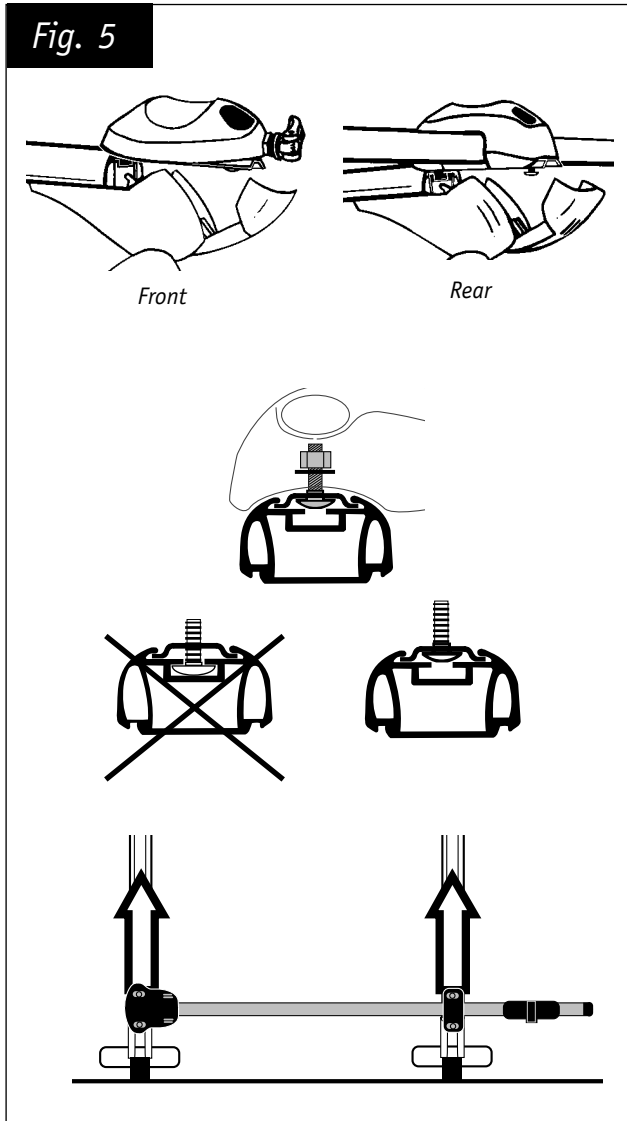
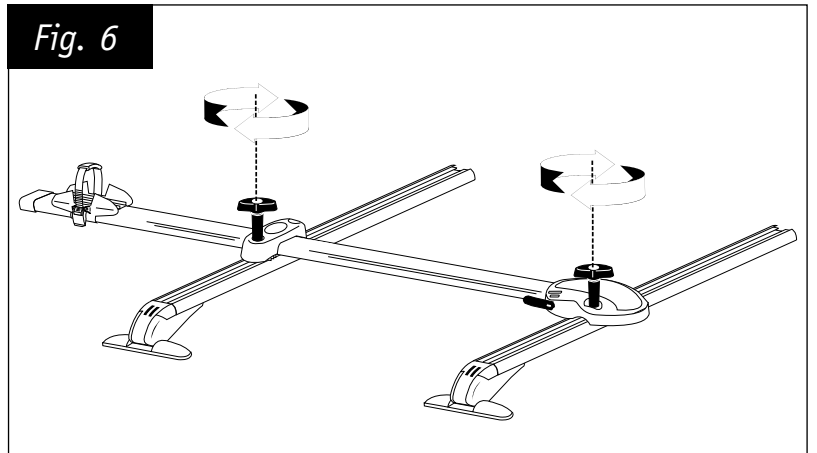
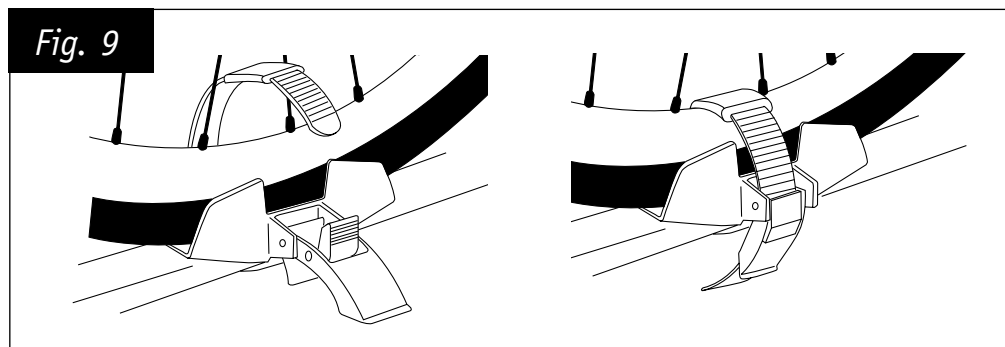
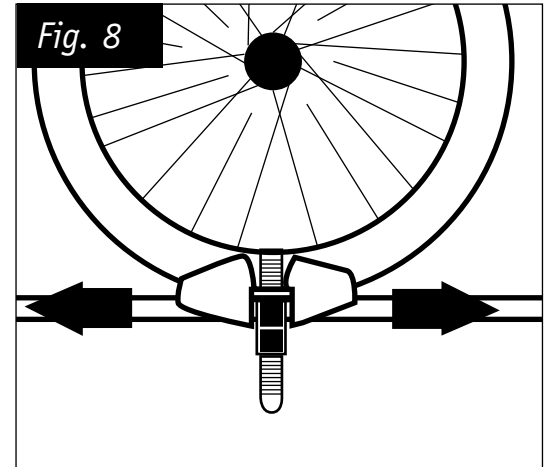
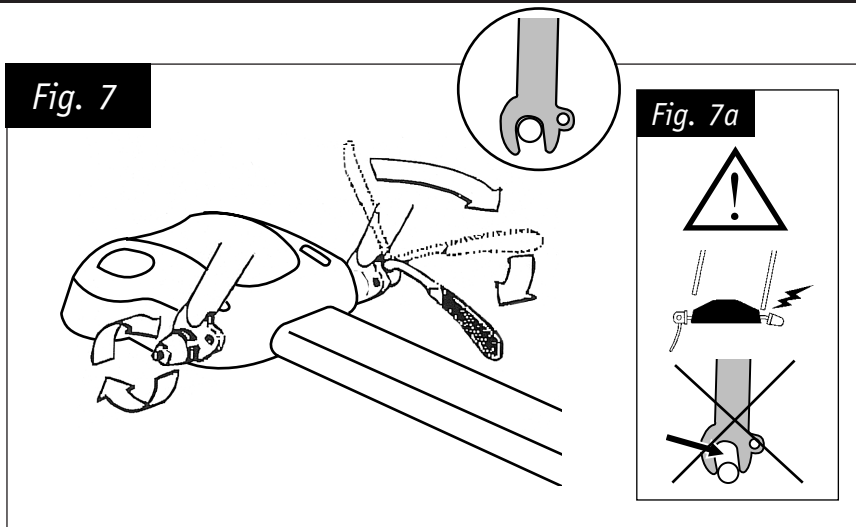

Fig. 6





Mounting your bicycle

1. Make sure your bicycle fork ends are both firmly and evenly mounted to the front of the Reinforcement Block– avoid situations as shown in figure 7a. Tighten the skewer such that the lever end requires enough force in closing that it leaves a small imprint on your hand. If the skewer lever closes too easily, tighten the nut side of the skewer and repeat until the lever is tight (see figure 7).
2. Position the Tire Holder under the rear bicycle wheel so that the center of the wheel is over the center of the Tire Holder (see figure 8).

Note: The Tire Holder is oriented with the adjusting side strap on the left side. If you mount the Fork Mount Carrier on the right side of the vehicle, you may find it helpful to reverse the position of the Tire Holder. To do this, remove the small screw under the rubber plug on the end of the Carrier. Remove the rubber plug, remove and reverse the orientation of the Tire Holder, and then re-install the plug and screw.

3. Use the Tie-down Strap to secure your rear wheel (see figure 9). See notes below for correct operation of the Tie-down Strap.

Operating the Tie-down Strap

1. Center the cushion of the rubber Tie-down Strap over the rim of the bicycle being held.
2. Feed the strap under the plastic push button and press down to activate the black metal locking mechanism.
3. To tighten, open and feed the strap further through.
4. To loosen, pull the strap up while pushing the button.
5. To open the strap, lift the metal locking lever and push the plastic button to unlock it. When not carrying a bicycle, fasten the wheel Tie-down Strap to avoid excessive wind noise.

For questions regarding installation call Performance Technical Support

M-F, 9-6 EST

1-800-553-8324



Performance Inc.

One Performance Way
Chapel Hill, NC 27514
Made in Canada

performancebike.com