

PERFORMANCE[®]

ViewPoint™ Dual Owner's Manual

Thank you for purchasing a ViewPoint™ Dual light system. All ViewPoint™ light systems are constructed of the highest quality materials, such as cold-forged aluminum housings, heavy duty cords with strong positive-click connections, and halogen bulbs with dichoric glass reflectors. Your ViewPoint™ Dual light system produces a clean light pattern for optimum visibility and is easily recharged for continued night riding enjoyment.

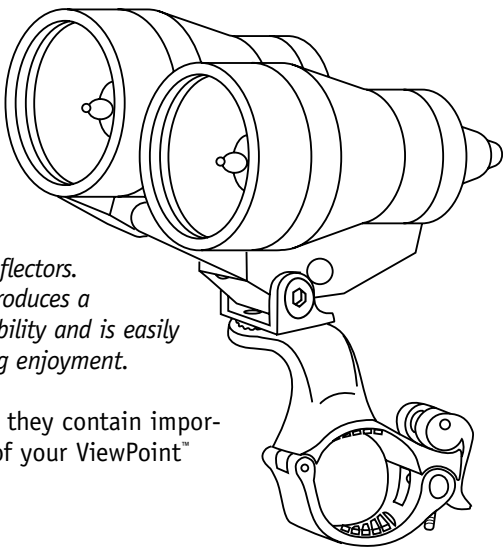

Please save these instructions, as they contain important information for taking care of your ViewPoint™ Dual light.

Installation and Use

Note: *Be sure to fully charge battery before first use (see the following section for details).*

1. Slide the battery into your waterbottle cage.
2. Install the headlight assembly onto your handlebar so that the headlight is positioned over the stem (see Figure 1).
3. Open the Quick Release Clamp, close the clamp around your bar, rotate the Quick Release Lever into position on the upper part of the clamp (with the lever pointing up) and then flip the Quick Release Lever downward to lock the clamp into position (see Figure 1).
4. If the clamp diameter setting is too loose or too tight, simply screw or unscrew the lever bolt as necessary to assure a secure grip on the bar.

5. Once you have your clamp tightness adjusted correctly, position your light as desired.

MAKE SURE THE CLAMP IS TIGHT ENOUGH THAT IT WILL NOT MOVE ON THE BAR FROM VIBRATION OR BUMPS.

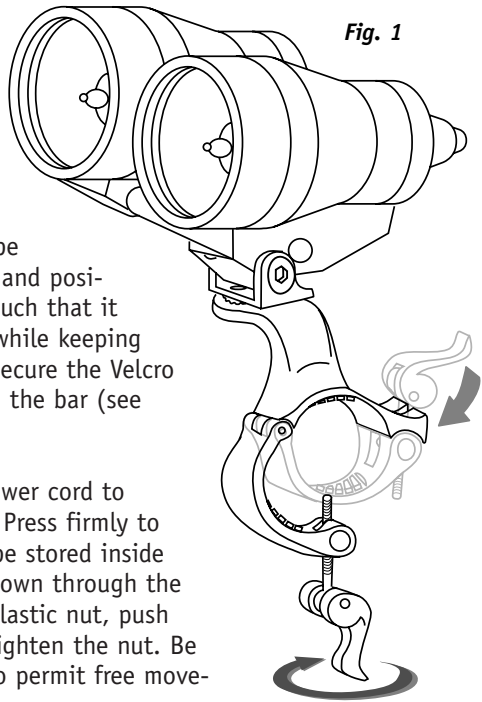

Fig. 1

6. Mount the Remote switch on the handlebar in a location that can be easily reached from your normal hand position. Ideally it should be placed such that it can be switched with the thumb while keeping the fingers near the brake lever. Secure the Velcro strap of the remote switch around the bar (see Figure 2).
7. Connect the locking end of the power cord to the locking end of the light cord. Press firmly to snap into place. Excess cord can be stored inside the battery bottle by pushing it down through the opening on the top. Loosen the plastic nut, push excess cord into the bottle, and tighten the nut. Be sure to leave enough cord slack to permit free movement of the handlebars.

8. **To operate:** Push the switch on the back of the light housing. The remote switch controls the second beam and allows the lights to be turned on or off independently of one another. The remote switch will allow the second light to be used only when needed, this will help to conserve battery power and extend the run time. Become comfortable with the switch operation before riding in the dark.

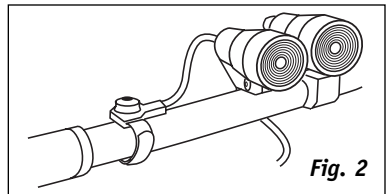

Fig. 2

9. A headlamp can be independently aimed by rotating the individual headlight up or down. After obtaining proper beam adjustment, securely tighten the bolts.
10. To remove the headlight assembly, flip the quick release and remove the entire assembly from your bike.
11. Your ViewPoint™ Dual comes with 12-watt spot and flood bulbs. The remote switch controls the flood bulb. You can customize the spot and/or flood control by swapping the bulbs or changing bulb type. Please refer to the section on changing bulbs. Please note that using the 15-watt or 20-watt bulbs (available as an optional accessory) will reduce the run time of your light.

NOTE: The high wattage bulbs cause the aluminum housings to get very hot when the light is in use. Therefore, DO NOT TOUCH THE ALUMINUM HOUSINGS WHILE THE LIGHTS ARE IN USE. Please use caution to avoid burning yourself. For optimum durability, your ViewPoint™ light should be mounted on your bicycle or helmet in such a way as to keep air flowing over the system.

Battery Charging

The ViewPoint™ battery *must* be recharged using *only* the 6V, 400mA lead acid compatible battery charger included with your light. Your ViewPoint™ light system uses a sealed lead acid battery. **It is extremely important that you always store your battery fully charged. A fully drained battery will be damaged beyond repair (this voids the warranty on the battery).** For the longest battery life, you should always recharge immediately after each use. ***Never use a NiCad or NiMH compatible charger on a sealed lead acid battery.***

1. Quick charge: Your battery can be charged to approximately 80% of its maximum charge in about 1 hour.
2. To guarantee a full recharge, leave the battery plugged in for 8 hours.

Your ViewPoint™ has a trickle charge feature which allows it to be left on recharge indefinitely, without harm.

Also available for your Viewpoint™ System

Battery Upgrade for all ViewPoint™ Sealed Lead Acid systems

The light weight powerful Nickel Metal Hydride (NiMH) waterbottle style battery will allow longer run times and is compatible with any ViewPoint™ Single or Dual system. Please note that the charger supplied with these (Sealed Lead Acid) systems will not work with the NiMH battery, so you *must* also order the charger if the battery is being used as an upgrade.

40-0324 NiMH 6.0 Ahr waterbottle style battery (requires NiMH recharger)

40-0339 NiMH battery charger (use only with NiMH battery)

00-8153 5.0 Ahr battery (replacement battery for ViewPoint™ Dual)

40-0026 15-watt intermediate bulb (20° beam)

00-8154 20-watt flood bulb (30° beam)

00-8152 12-watt spot bulb (10° beam)

00-2365 12-watt flood bulb (30° beam)

Bulb Replacement – Read Carefully!

Take care when replacing the lamp in order not to damage the bulb connection.

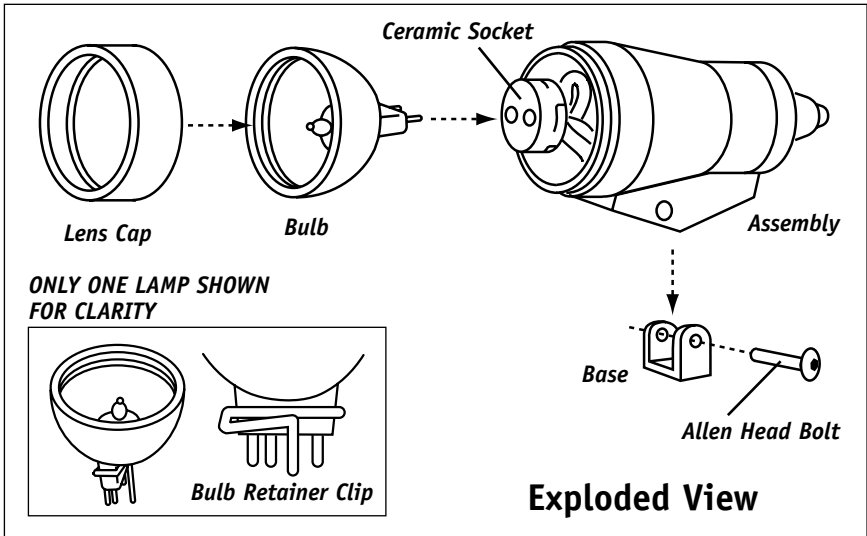

1. Disconnect headlamp from battery pack.
2. To remove the bulb, carefully unthread the lens cap. Do not allow the bulb to rotate. It may be necessary to press down gently on the bulb while unthreading the cap.
3. Unplug the used bulb and discard it.
4. To install the bulb, first insert the two prongs of the retainer clip into the larger holes on the ceramic socket. Next, insert the bulb lead wires into the smaller holes in the socket.
5. Rethread lens cap onto housing. Make sure the lens cap thread is fully engaged with the housing. Do not plug the lamp into the battery until after this step is complete.

For technical support, call 1-800-727-2453 from 9am - 6pm Monday through Friday.



Performance, Inc.

One Performance Way
Chapel Hill, NC 27514

www.performancebike.com

1-800-727-2453