

**PERFORMANCE**

**XPORT**  
**XPress**

# Wheel Carrier

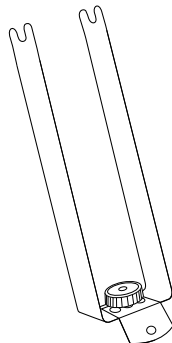

Thank you for choosing the XPORT XPress Wheel Carrier. This Wheel Carrier is designed to hold the front wheel of an ATB or road bike, and can be folded down when not in use. The XPORT XPress Wheel Carrier is made to mount easily, quickly and exclusively to the XPORT XPress Roof Rack System.

## Please read and understand the following roof rack guidelines:

**⚠ WARNING:** Pay particular attention to the vehicle manufacturer's roof weight bearing recommendation. For security and safety, you must refer to the vehicle manufacturer's guidelines for the permissible weight for a roof top carrier.

- Use only racks or accessories that are compatible with the XPORT XPress Roof Rack System, and only for vehicles listed in the XPORT XPress Fit Guide.
- Do not carry more than 165 lbs on the XPORT XPress Crossbars. Use of the XPORT XPress rack does not increase gutter or roof strength. Misuse can result in damage to vehicle, gear and rack. Other vehicles can be damaged and people can be hurt or killed in accidents caused by a rack falling from a vehicle. **Caution: It is the consumer's responsibility to ensure safe and proper installation.**
- Read and follow the instructions carefully.
- Drive safely. Do not exceed the posted speed limit while using the rack.
- Please note that vehicles handle differently when a roof rack is fitted, and especially when loaded. Vehicles may corner and brake differently, and may be more vulnerable to side winds.
- It is essential that all connections and accessory attachments be tightened correctly and checked at regular intervals.
- For reasons of safety and fuel efficiency, removal of the rack is recommended when not in use.
- The rack may limit the operation of some sun roofs.
- Clean with mild soap and water only. Some chemicals can damage nylon and rubber parts.

For questions about your XPORT XPress installation call Performance Technical Support at 1-800-553-8324, M-F, 9-6 EST

These instructions assume that you already have an XPORT XPress Roof Rack (Hook Kit, Foot Pack and Crossbars) mounted to your vehicle. To properly install the roof rack, please see the instructions included with the XPress Crossbar. Read and understand the Warnings included with your XPORT XPress Roof Rack.

## Assembly & Installation

If you are mounting this carrier to a rack with the Foot Kit already open, proceed to step 5.

1. Push the lock cover up to expose the keyhole (see figure 1).
2. Unlock the mechanism with your key. Pull the Black Ratchet Lever back without clicking the ratchet mechanism (see figure 2).
3. Push forward on the Yellow Release Lever that is now exposed, while applying light pressure to the Ratchet Lever. The hook attached to your vehicle will release (see figure 2).
4. Push the Black Ratchet Lever closed, creating slack (no tension) on the steel strap. The Black Lever can then be opened fully (see figure 3).
5. Remove the rubber trim strips from the top of the Foot Assemblies and/or Crossbars (depending on where the Fork Mount Carrier is to be mounted on the rack).
6. Slide the steel plate of the Wheel Carrier onto the XPORT XPress bar rail (see figure 4). **Caution:** *The carriage bolt of the Wheel Carrier must go into the top rail of the Foot Assembly/Crossbar only (see figure 5).*
- Note:** Position the Wheel Carrier such that it is pointed up and angled slightly towards the rear of the vehicle.
7. Tighten the knob on the Wheel Carrier to secure the carrier to the Crossbar (see figure 6).
8. Replace Rubber Trim pieces as needed, by cutting sections to fit in the open channel.

## Closing the locking foot mechanism

1. After the Wheel Carrier is installed, close the locking foot. Pull back on the Black Lever slowly to tighten the Hook Kit onto the vehicle's roof edge. Hold the Hook in position, being careful not to move the bar from its position (see figure 7). **Caution:** *Do not pull the Black Lever past vertical or use excessive force to tighten. The XPORT XPress lever mechanism provides considerable mechanical advantage and can damage your vehicle if overtightened.*
2. Put your wheel into the Wheel Carrier drop outs and tighten the quick release to secure the wheel. Refer to your bicycle owner's manual for the correct use of your quick release (see figure 8).

 **WARNING:** Failure to properly install your Wheel Carrier can cause the wheel to come loose, possibly damaging your wheel or vehicle, and possibly injuring others on the road.

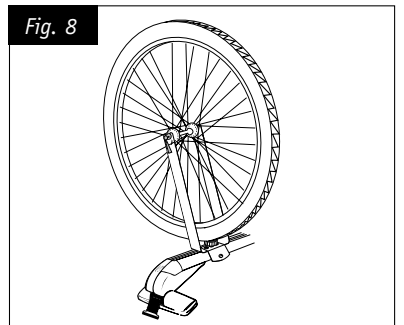
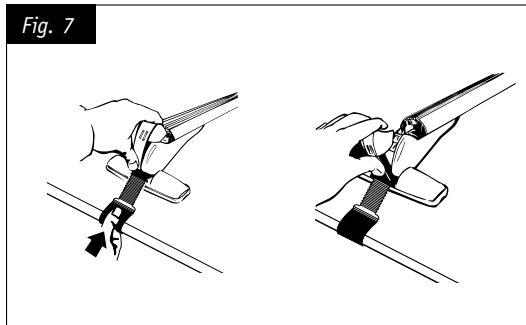
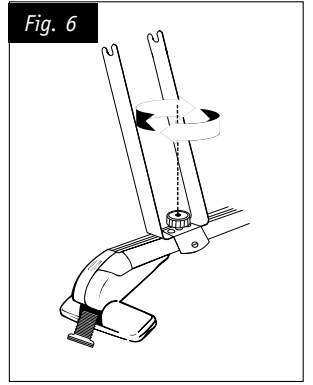
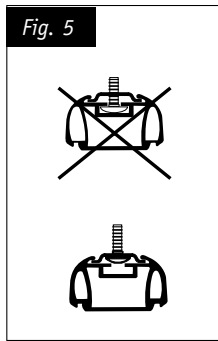
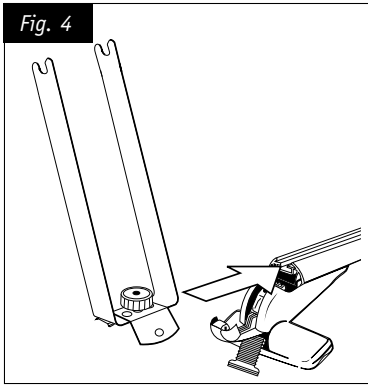
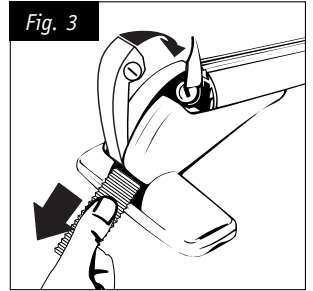
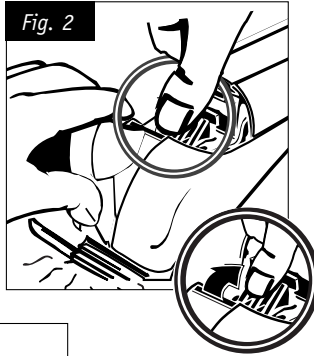
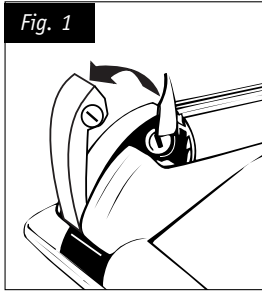

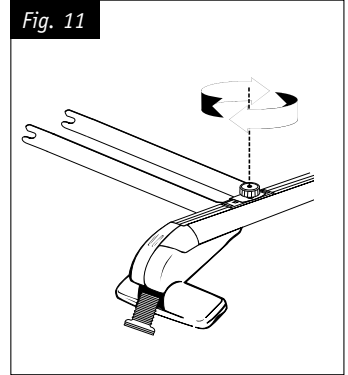
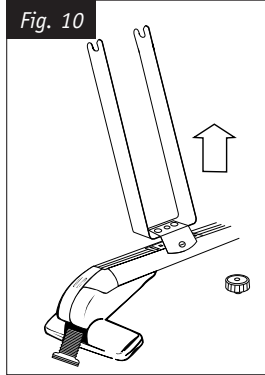
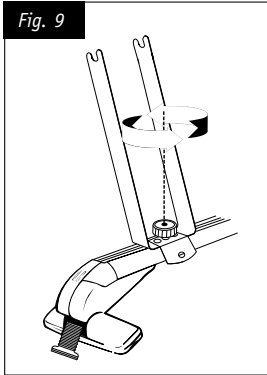

### **Folding the Wheel Carrier:**

When not in use the XPORT XPress Wheel Carrier can be folded down.

1. Loosen and remove the knob (see figure 9).
2. Remove the Wheel Carrier vertically (see figure 10).
3. Lay the Wheel Carrier back, pointed toward the rear of the vehicle, and replace the knob on the side plate of the Wheel Carrier (see figure 11).

*For questions regarding installation call Performance Technical Support*

**M-F, 9-6 EST**

**1-800-553-8324**



**Performance Inc.**  
One Performance Way  
Chapel Hill, NC 27514  
Made in Canada  
[performancebike.com](http://performancebike.com)