

Ski Kit

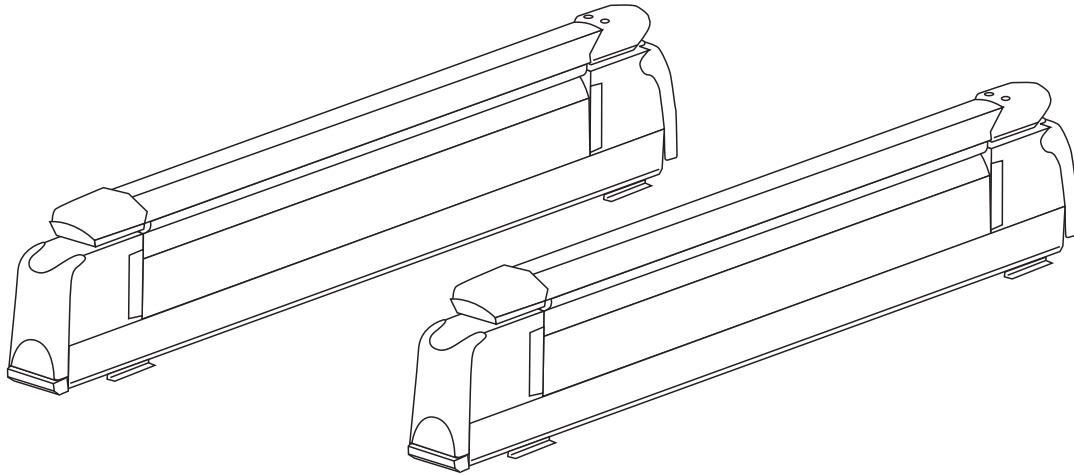

Thank you for choosing the XPORT XPress Ski Kit. This kit is designed to carry both skis and snowboards. The XPORT XPress Ski Kit is made to mount easily, quickly and exclusively to the XPORT XPress Roof Rack System.

Please read and understand the following roof rack guidelines:

⚠ WARNING: Pay particular attention to the vehicle manufacturer's roof weight bearing recommendation. For security and safety, you must refer to the vehicle manufacturer's guidelines for the permissible weight for a roof top carrier.

- Use only racks or accessories that are compatible with the XPORT XPress Roof Rack System, and only for vehicles listed in the XPORT XPress Fit Guide.
- Do not carry more than 165 lbs on the XPORT XPress Crossbars. Use of the XPORT XPress rack does not increase gutter or roof strength. Misuse can result in damage to vehicle, gear and rack. Other vehicles can be damaged and people can be hurt or killed in accidents caused by a rack falling from a vehicle. **Caution: It is the consumer's responsibility to ensure safe and proper installation.**
- Read and follow the instructions carefully.
- Drive safely. Do not exceed the posted speed limit while using the rack.
- Please note that vehicles handle differently when a roof rack is fitted, and especially when loaded. Vehicles may corner and brake differently, and may be more vulnerable to side winds.
- It is essential that all connections and accessory attachments be tightened correctly and checked at regular intervals.
- For reasons of safety and fuel efficiency, removal of the rack is recommended when not in use.
- The rack may limit the operation of some sun roofs.
- Clean with mild soap and water only. Some chemicals can damage nylon and rubber parts.

For questions about your XPORT XPress installation call Performance Technical Support at 1-800-553-8324, M-F ,9-6 EST.

These instructions assume that you already have an XPORT XPress Roof Rack (Hook Kit, Foot Pack, and Crossbars) mounted to your vehicle. To properly install the roof rack, please see the instructions included with the XPORT XPress Roof Rack Components.

Assembly & Installation

If you are mounting this carrier to a rack with the Foot Kit already open, proceed to step 5.

1. Push the lock cover up to expose the keyhole (see figure 2).
2. Unlock the mechanism with your key. Pull the Black Ratchet Lever back without clicking the ratchet mechanism (see figure 3).
3. Push forward on the Yellow Release Lever that is now exposed, while applying light pressure to the Black Ratchet Lever. The hook attached to your vehicle will release (see figure 3).
4. Push the Black Ratchet Lever closed, creating slack (no tension) on the steel strap. The Black Lever can then be opened fully (see figure 4).
5. Remove the Rubber Trim strips from the top of the Foot Assemblies and/or Crossbars (depending on where the Fork Mount

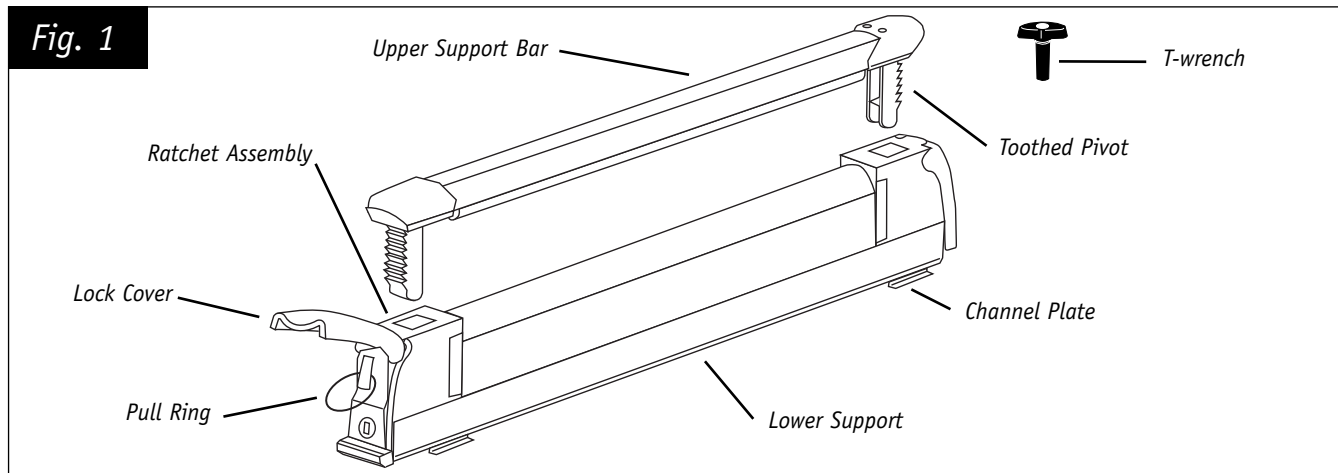

Carrier is to be mounted on the rack).

6. Slide the Channel Plates into the open channel in the top of the Foot Assembly and Crossbar. (see figure 5).

Note: Do not remove the nuts holding the Channel Plate. Make sure that the Channel Plate is properly inserted into the Crossbar Channel (see figure 6.)

7. Once the Kit is placed in the desired position, use the "T-wrench" included with the Ski Kit to tighten the Channel Plate nuts. Tighten the nuts on both sides of the Ski Kit until the nylon portion of the nut is threaded on to the bolt (see figure 7).

8. Replace the Rubber Trim pieces as needed, by cutting sections to fit in the open channel of your crossbar.

9. Close the Black Ratchet Lever. If the Hook Kit was loosened during the installation, retighten by slowly pulling back on the Black Ratchet Lever (while holding the Hook in position).

Caution: Do not pull the Black Lever past vertical or use excessive force to tighten. The XPORT XPress lever mechanism provides considerable mechanical advantage and can damage your vehicle if overtightened.

Mounting your Skis or Snowboards

1. Lift the hinged Lock Cover to expose the Pull Ring. If the Pull Ring cannot be pulled, use the key in the lock mechanism to unlock the Pull ring. Repeat for the other side (see figure 8).
2. Lift up on one side of the Upper Support Bar while the Pull Ring is pulled to remove it from the Lower Assembly (see figure 8).

Note: For convenience, the Upper Support Bar is hinged and can be opened from either side without removing the entire Bar.

Skis

Place the skis on the Lower Support with the ski tips facing towards the rear of the vehicle. Secure the skis with the Upper Support Bar by inserting the Toothed Pivot into the Ratchet Assembly.

Note: The Upper Support Bar can be adjusted to different heights depending on the thickness of skis or snowboards. When installing skis or snowboards with varying thicknesses, please refer to fig 9A for proper mounting.

Snowboards

Position snowboards with rigid bindings toward the top. Place the snowboards with collapsible and plate bindings towards the bottom. Remove the bindings on the lower snowboard before installation (see figure 10).

Note: Be sure to lock both sides of the Upper Support Bar on each kit after skis or snowboards are mounted.

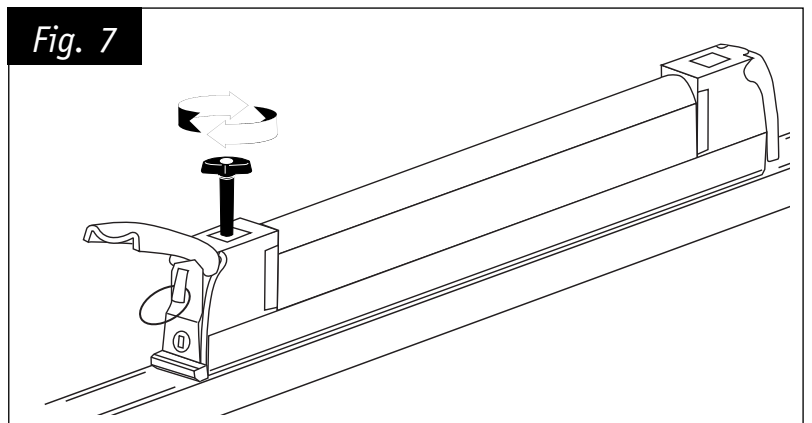
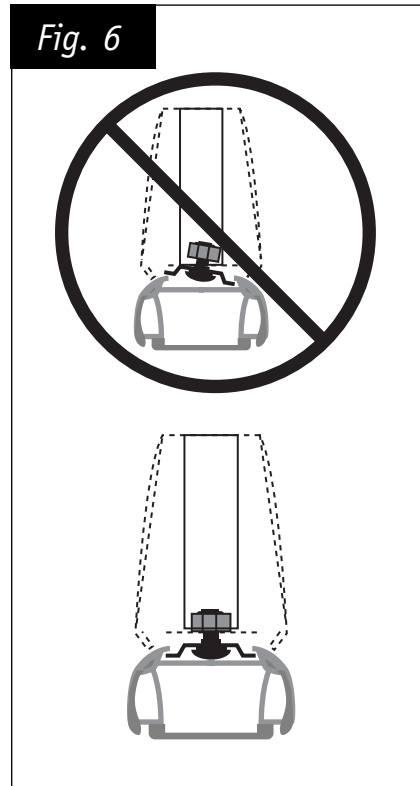
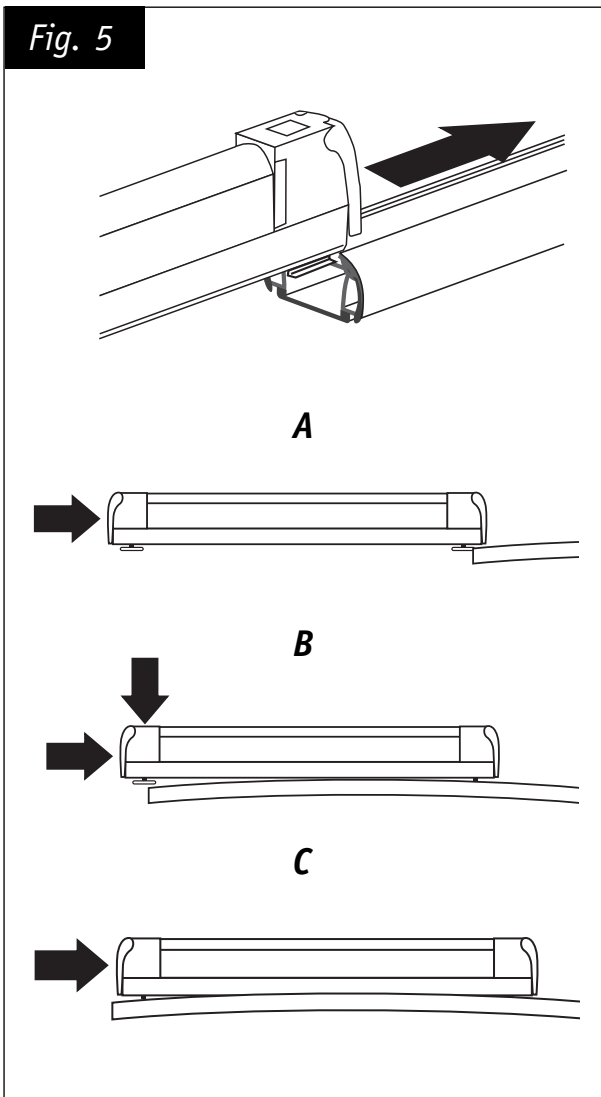
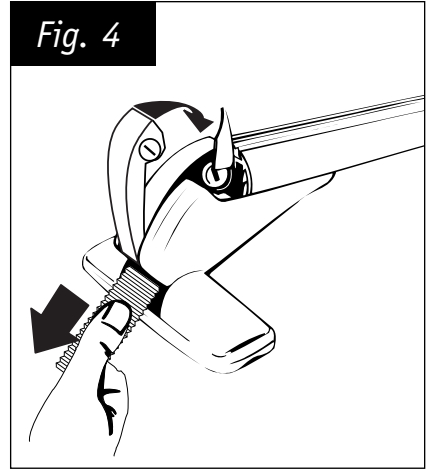
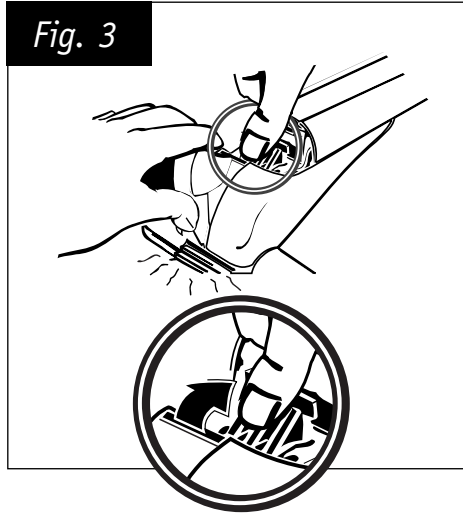
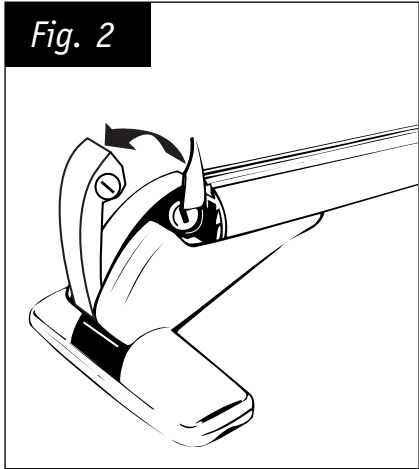

Fig. 8

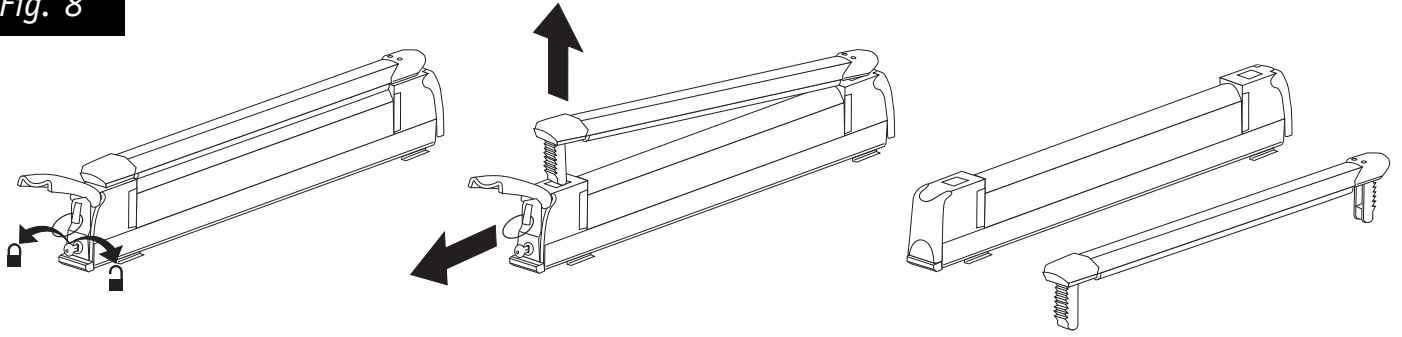

Fig. 9

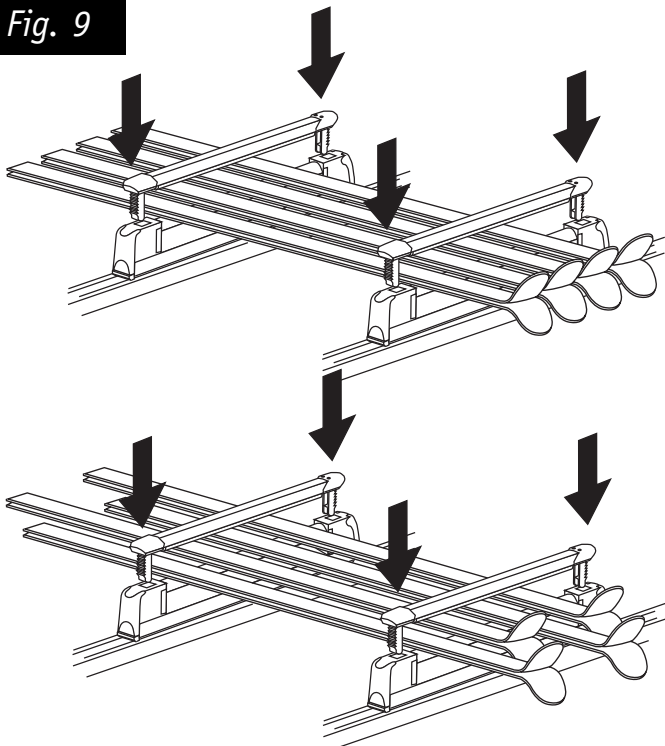

Fig. 9A

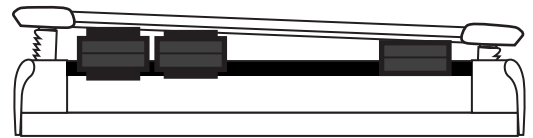
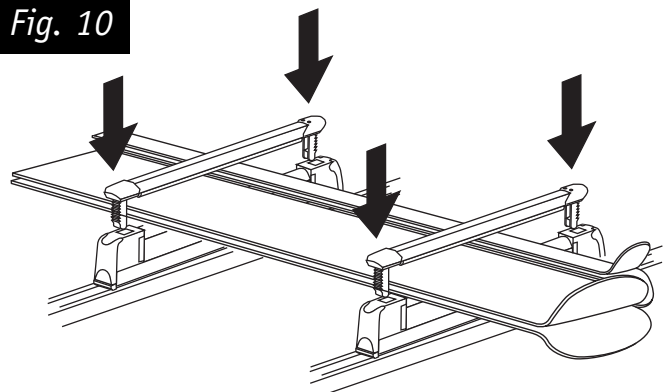

Fig. 10



For questions regarding installation call Performance Technical Support
M-F, 9-6 EST
1-800-553-8324



Performance Inc.
One Performance Way
Chapel Hill, NC 27514
Made in Canada
PerformanceBike.com