

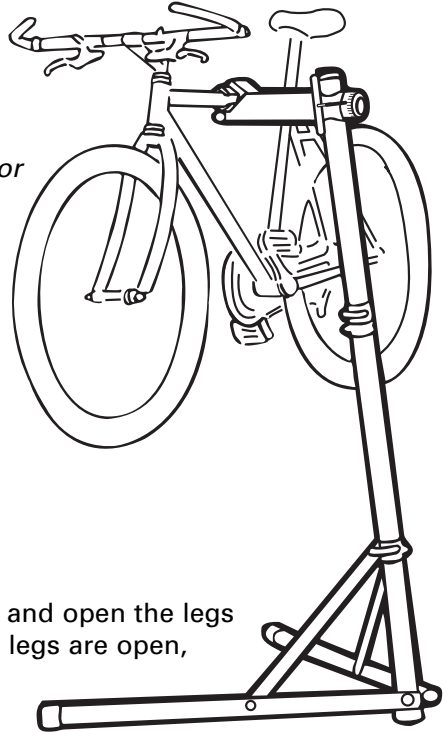

Spin Doctor Pro 2 Workstand

Thank you for purchasing the Spin Doctor Pro workstand. The unique features and design combine to create a workstand that's simple to use, easy to carry, and convenient to store. Your new stand is completely assembled and ready to go, but please read the instructions carefully before use.



Workstand Set-up

1. Loosen the quick release lever 1 (QR1) and open the legs at the end of the bracket. Once the legs are open, tighten the QR1 to lock them in place. (Fig 1)
2. Loosen the quick release lever 2 (QR2) and extend the upper frame. When the upper frame is positioned at the height you need, tighten QR2 to hold it in place. (Fig 2)
3. Loosen the round clamp assembly knob and raise the clamp arm. Retighten the knob after raising the clamp arm. (Fig 3)

Note: To prevent accidental collapse of the stand, or falling of the bicycle, be sure to tighten the quick release levers securely. The stand has a built in safety stop that ensures the correct positioning of the clamp arms and tubes. Do not attempt to modify these settings.

4. Push the spring loaded clutch lever to allow the clamp head to rotate. Release the lever when the clamp head is in the desired position.

How To Clamp The Bicycle:

5. Adjust the firmness of the clamp jaw by turning the knob on the clamp lever. The space between the jaws will become smaller as you turn the knob clockwise and will open wider as you turn the knob counter-clockwise. *(Fig 4)*
6. To open the clamp jaw, push the lever down. Raising the lever will close the jaws. Be sure the lever is securely closed when you place the bike in the clamp. *(Fig 5)*

Note: (1) When operating the clamp lever, be sure to keep your fingers away from the jaws in order to avoid injury.

(2) As with any stand, over tightening the clamp may result in damage to your bicycle. Please be especially cautious when clamping bicycles with frames made of carbon fiber or thin-walled tubing.

Adjusting The Height:

7. To raise the stand height, loosen the QR2 and extend the upper frame by pulling it up with your hand. Tighten the QR2 once the proper height is reached. *(Fig 6)*

Note: Height adjustments should be made before you clamp the bike. If you attempt to adjust while the bike is clamped in the stand, be sure to hold the the bike with your other hand to keep top position of the stand from abruptly sliding down.

▲ CAUTION

- A. You must fully open the stand legs to the safety-stop to ensure proper stability. *(Fig 7)*
- B. Be sure to place the Spin Doctor Pro stand flat on the ground to prevent accidental tipping or falling.
- C. If quick release levers are not firmly tightened, it may result in accidents such as the sudden dropping of the bike or pinching of fingers between the jaws. Always securely tighten the quick release levers, and keep fingers away from sliding areas of the stand.



(Fig 1)

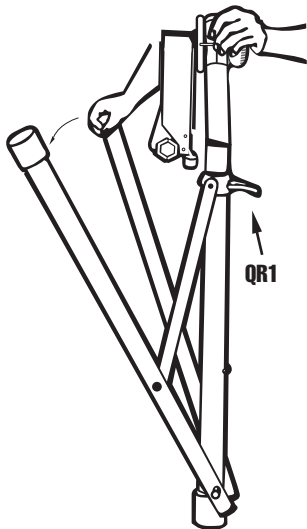

(Fig 2)

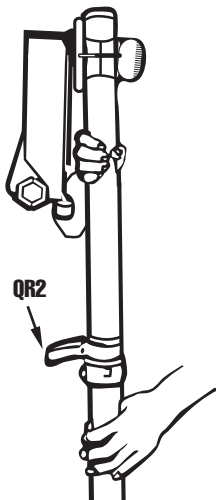

(Fig 3)



(Fig 3)

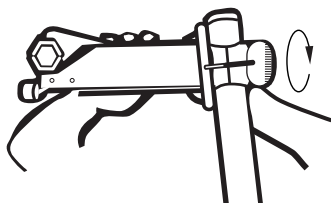

(Fig 4)

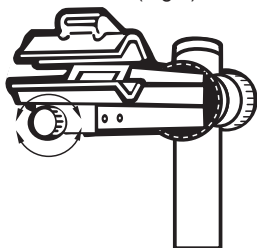

(Fig 6)

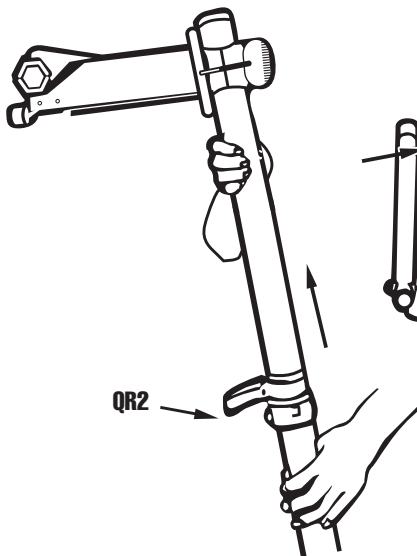

(Fig 7)

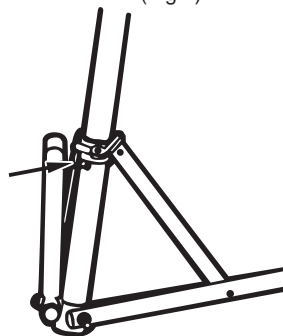

(Fig 5)

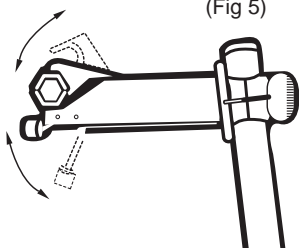

Tech Support Line 1-800-553-8324



Performance, Inc.

One Performance Way

Chapel Hill, NC 27514

PerformanceBike.com

**PERFORMANCE and the Flying P logo are
registered trademarks of Performance Inc.**

Made in Japan