

PERFORMANCE[®]

XPORT[™]

Optional Front Wheel Holder (00-3709)

The Front Wheel Holder is designed to carry a front wheel for a mountain or road bike. It is to be used in conjunction with the XPORT[™] Truck Rack which is sold separately.

Please read these instructions *before* mounting the XPORT[™] Truck Rack to your truck.

Part No.

Qty.

3 Fork Assemblies	1
3a Rubber Pad	1
3b Fork Clamp	2
3c 2" Carriage Bolt	1
3d Fork Mount Knob	1
7. Fork	

Tools Required

Slotted screwdriver
Phillips screwdriver

Assembly Instructions

1.0 Building the Fork Mount Assemblies

Please refer to the illustrations on page 2.

- 1.1 Wrap the rubber pads around the Crossbrace and loosely assemble the Fork Clamps (part 3b), Carriage Bolt (part3c), and Fork mount Knob (part3d) over the rubber pad, see **Figure 1**.
- 1.2 Once the Fork Mount Knob... (see **Figure 2**). Take note that the Fork Mount Assemblies are positioned straight up as shown in **Figure 2**, and tighten down the Fork Mount Knob.
- 1.3 Install the Quick Release Skewer (Part 3f) into the Skewer Guide (Part 3e) and thread the Quick Release Nut (Part 3g) on the Quick Release Skewer. See **Figure 2**.
- 1.4 Repeat from step 2 above for the second Fork Mount Assembly.

2.0 Use

- 2.1 Position the Front Wheel Holder on the truck Rack such that it does not interfere with bicycle.
- 2.2 Tighten the Fork Mount Knob securely to keep the Fork from rotating on the Truck Rack.

Performance Tech Support 1(800)553-8324 9am-6pm EST Monday-Friday

Continued...

3.0 Safety Precautions

- 3.1 Always keep the tail gate closed or retaining net in place when using the XPORT™ Truck Rack.
- 3.2 If you leave the Truck Rack on your truck, check the tightness of the rack before each use.
- 3.3 Check the Cork Gaskets for wear periodically. Worn or torn Cork Gaskets could cause the Truck Rack to slip and should not be used. Order replacement pads from our Technical Service Department at 1-800-727-2453 (9am to 6pm EST).
- 3.4 The Truck Rack will hold a maximum of Four single person bicycles or two tandem bicycles. Do not over-load the Truck Rack.
- 3.5 Due to increased wind resistance, it is advisable to remove child seats, panniers, wheel covers, or full bike covers from your bicycles during transport.
- 3.6 To avoid personal injury, do not ride in the bed of the truck with Truck Rack installed.

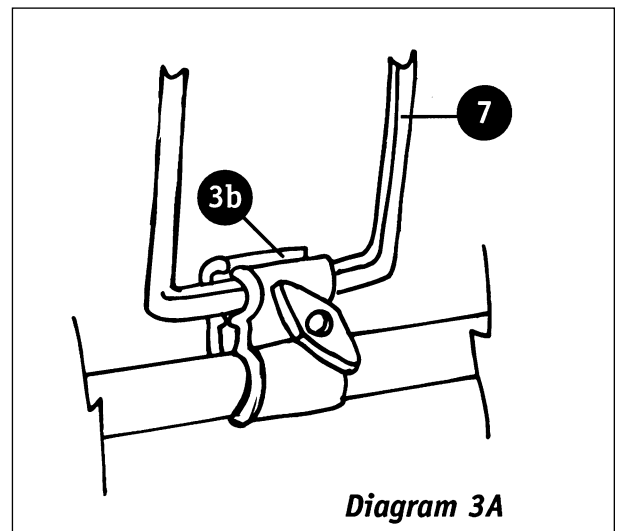
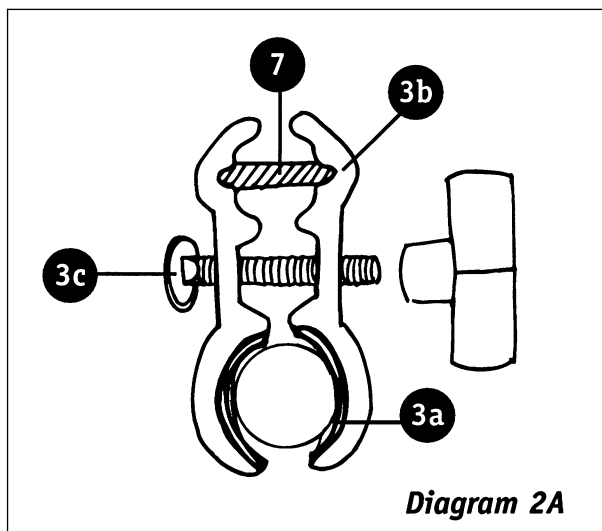

Performance, Inc.

One Performance Way
Chapel Hill, N.C. 27514
Made in USA

www.PerformanceBike.com

PERFORMANCE and the Flying P Logo are registered marks of Performance Inc.