

XPORT[™]

Traveler 2" Receiver Hitch Foot

Thank you for purchasing the XPORT Traveler 2" Receiver Hitch Foot. When used with the XPORT Traveler Uprights, this Hitch Foot allows easy installation and removal from your vehicle, without tools.

Please read all instructions for Assembly and Installation to your Vehicle before using your XPORT Hitch rack.

Notes:

1. The XPORT 2" Receiver Hitch Foot is designed to be used with XPORT Traveler Hitch Racks. Instructions for attaching the 2" Receiver Hitch Foot to the Upright are included with the Upright assembly instructions.
2. The minimum vehicle hitch requirement is a Class 1, bolted to the chassis.
3. Some vehicles, particularly those with step bumpers, a rear mounted spare tire or a recessed hitch, will require the use of the XPORT Hitch Extension sold separately.
4. Bicycles can be locked to the rack and the rack to the vehicle by using the XPORT XCLOSURE II Lock also available separately.

CAUTION: IT IS THE USER'S RESPONSIBILITY TO INSURE THE SAFE AND PROPER USE OF THIS PRODUCT!

Improper attachment or misuse of this Hitch Foot or rack may result in damage to the bicycles, your vehicle or the vehicles behind you on the road.

Contents

Part	Part Code	QTY
Hitch Foot	A	1
Plastic Knob	B	1
Clevis Pin	C	1
Clevis Pin Clip	D	1
Washer	E	1

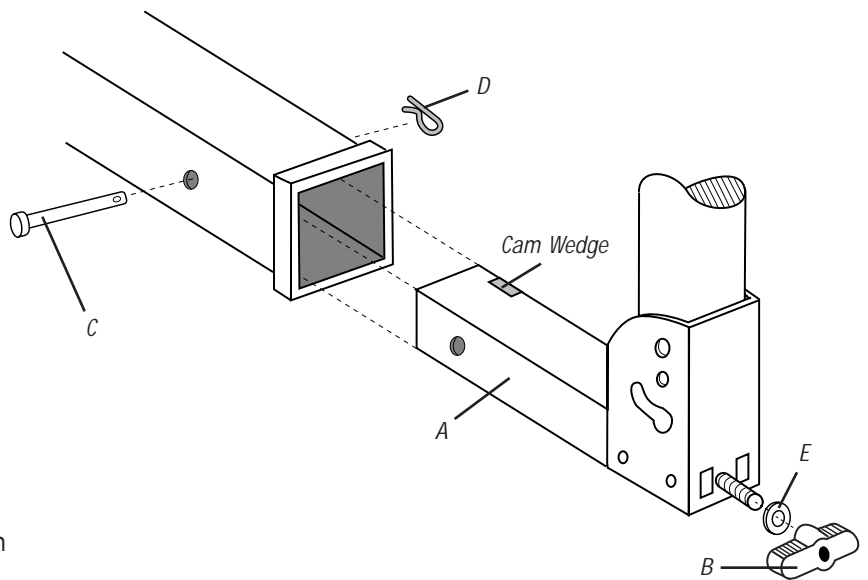

Assembly

1. Slide the Washer (E) over the threaded rod on the Hitch Foot (A). Thread the Plastic Knob (A) loosely onto the threaded rod.
2. Refer to the Assembly instructions included with your Hitch Rack Upright for attaching the 2" Receiver Hitch Foot to the Upright.

Installation to Vehicle

1. Insert the Hitch Foot (A) into the receiver hitch. If the Hitch Foot (A) does not slide easily into the receiver hitch, loosen the Plastic Knob on the Hitch Foot, and lightly push on the knob until the cam wedge is recessed into the Foot.
2. Align the Hitch Foot pin hole with the pin hole in the receiver hitch. Insert the Clevis Pin (C) through the pin hole and snap on the Clevis Pin Clip (D).
3. Tighten the Plastic Knob (B) to stabilize the rack in the receiver hitch.
4. Double check the tightness of the Plastic Knob (B) after the first 10 minutes of travel and occasionally during a trip.

Traveler 2" Receiver Hitch Foot

5. To remove the the rack, loosen the Plastic Knob (B), remove the Clevis Pin Clip (D) and Clevis Pin (C), and remove the rack from the hitch.

If the Rack is difficult to remove from the hitch, loosen the knob and tap it slightly to recess the cam wedge.

WARNING: ALWAYS KEEP THE CLEVIS PIN INSTALLED WHEN THE RACK IS MOUNTED ON THE HITCH!

**Performance Tech Support 1 (800)727-2453
9am-6pm EST Monday-Friday**