

# PERFORMANCE®

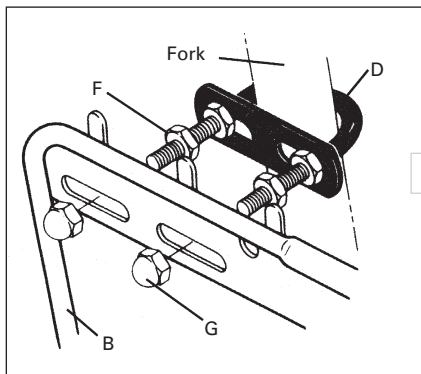

3. Locate parts: A, B and G.

4. Attach the Right Rack Frame (B) onto the right fork blade using the acorn nuts (G). Tighten the "U" Bolt nuts (F) against the back side of the rack frame. Repeat on the left side with the left rack frame (A). (See Figure 3)

**Note:** The "TransIt" logo on the Left and Right Rack Frame should face outwards.

5. Attach the lower 'L' bracket of the Right Rack Frame (B) and the tip of the Center U Frame (C) to the fork eyelet using the appropriate length bolt and locknuts (H) (J). Repeat on the left side. (See Figure 4) A round aluminum spacer (I) placed between the rack and fork eyelet may be required.

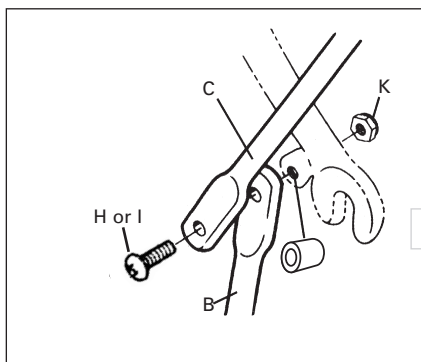

6. Locate the following parts: K, L and M.

7. Attach a small clamp (K) on the right side of the Central U Frame with the flat side against the forward corner of the Right Rack Frame (B). Install the bolt (H) and lock nut (J). Repeat on the left side. (See Figure 5)

8. Make sure the bike is on a level surface, then align the rack so that the top horizontal surfaces of the Right and Left Rack Frames are parallel to the ground

9. Tighten all the bolts and nuts and ensure that the rack is secure on the fork. Be careful not to damage the fork when tightening the 'U' bracket nuts (F).

10. Refer to pannier manufacturer's instructions for mounting panniers.

11. Always mount the panniers carefully. Check to be sure that the pannier's attachment hardware is correctly installed and secure. Check carefully to be sure that the rack and panniers do not interfere with your bicycle's braking system or wheels. The lower pannier hook should be positioned in the notch at the bottom of the Rack Frame.

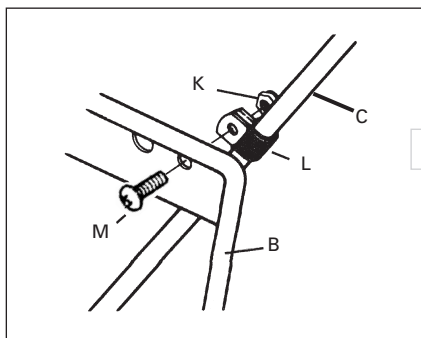

12. Ensure that panniers are very securely mounted on the Front Pannier rack. While riding, stop periodically to be sure the rack and panniers are secure.

**Performance Tech Support 1(800)553-8324  
9am-6pm EST Monday-Friday**



**Performance, Inc.**  
One Performance Way  
Chapel Hill, N.C. 27514  
Made in China  
[www.performancebike.com](http://www.performancebike.com)

PERFORMANCE and the Flying P Logo are registered marks of Performance, Inc.

20-2084 8-25-04