



PANNIERS

Thank you for purchasing a pair of TransIt™ panniers. With a little care, your TransIt™ panniers will perform for mile after mile of touring and commuting.

Attaching Panniers to Your Bike:

Panniers are sold as a pair, which includes one left and one right pannier. Left and right are from the perspective of a rider on the bicycle.

1. Make sure the rack to which the panniers will be attached is level and securely attached to the bicycle.
2. Lift the right pannier onto the rack so the top hooks (A) rest securely over the top rail.
3. Attach the lower hook (B) to a secure point on the lower portion of the rack.
4. Pull up firmly on the tension strap (C) to secure the pannier to the rack.
5. Check the security of the attachment by gripping the pannier and trying to move it from side to side. If it is not secure, tighten the tension strap a bit more and check again.
6. Clip the male end of the tension strap buckle (D) into the female end of the buckle (E).

! WARNING

Before riding, make sure that the tension strap is secure and cannot contact the wheel or spokes in any way.

7. If your heels strike the rear panniers during the pedal stroke, loosen the tension straps, move the panniers further toward the rear of the rack and retighten securely.

Removing Panniers:

1. Unclip the male end of the tension strap buckle (D) from the female end of the buckle (E).
2. With your thumb, press the top of the tension strap slider buckle (F) away from the pannier to release tension in the strap.
3. Grip the pannier and pull up until the top hooks are free from the rack. Then lower the pannier to release the lower hook from the rack.

Loading Your Panniers:

For maximum stability, pack heavy items as low and as close to the bike as possible. Keep in mind that your bicycle will handle differently when fully loaded. The additional weight of front and rear panniers will affect starting, braking, steering and turning. In particular, your bicycle will require more time to stop; you must think further ahead to anticipate stops and turns.

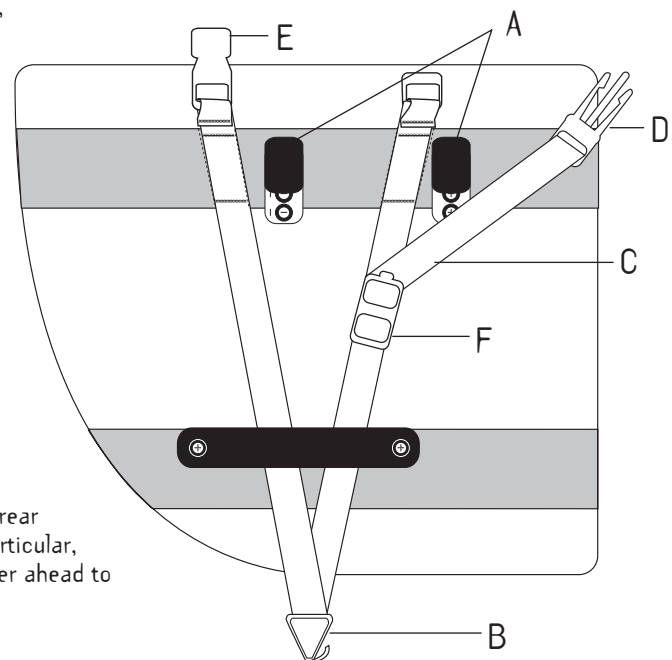

Tech Support 1(800)553-8324

Made in Malaysia

0107_1
20-1486/20-1487