

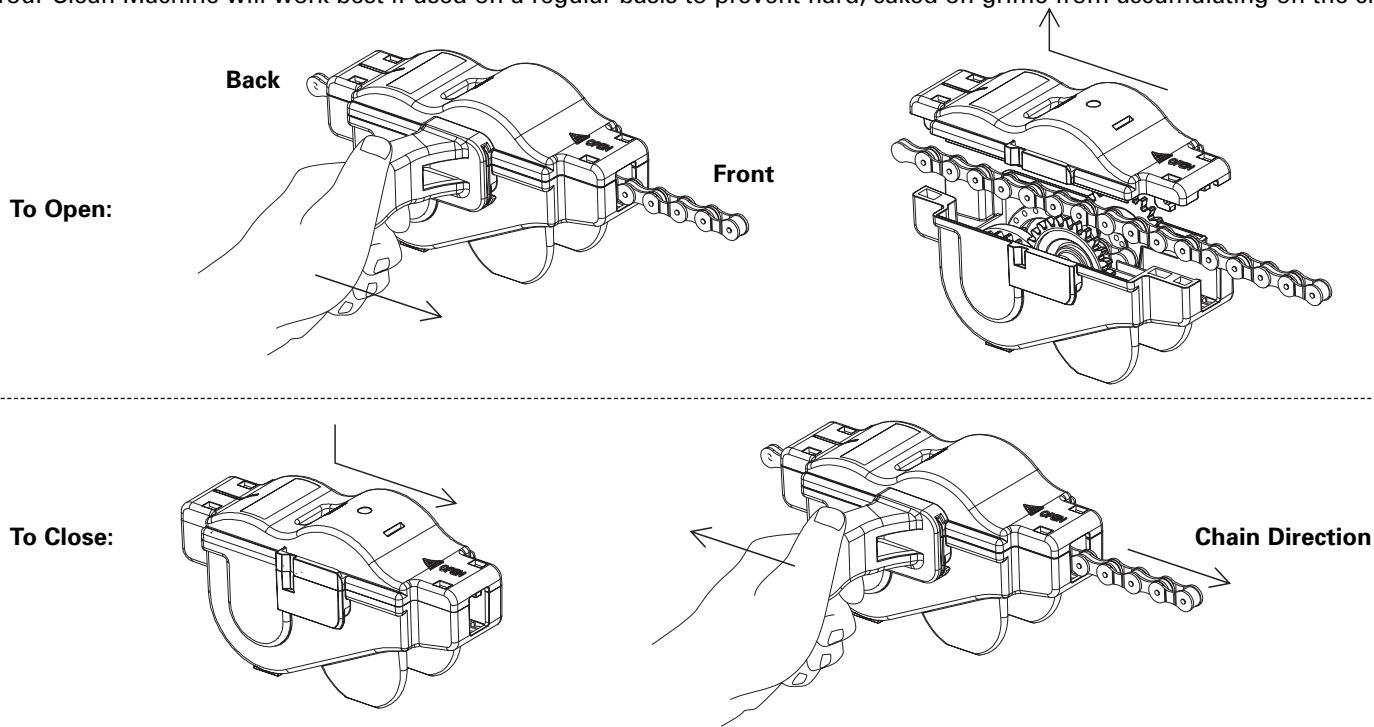

# Clean Machine Chain Cleaning Tool

***Congratulations on your purchase of the Spin Doctor™ Clean Machine. To ensure the best performance when cleaning your chain, please review the instructions below.***

1. Cover the work space with newspapers or rags to catch excess cleaning fluid that may drip from the chain during cleaning.
2. Remove excess mud, dirt and grime from the chain using the Spin Doctor™ Cog Brush or a shop rag.
3. Stabilize the bike in a repair stand and shift the chain into the middle or small chain ring up front, and the middle of the cog set in the rear. Adjust the bike so that the lower portion of the chain is parallel with the ground.
4. Remove the locking handle by depressing the thumb lever and sliding the handle forward. Then remove the lid by sliding it rearward and lifting. Add enough Performance® CleanSafe™ degreaser or other cleaning fluid to reach the "FILL" line on the side of the reservoir. To avoid spills, do not overfill.
5. Position the Clean Machine on the lower portion of the chain, mid-way between the cog set and crank set, and replace the lid, making sure it is completely flush with the reservoir body. Slide the locking handle into place. You should hear an audible "CLICK" to indicate the handle is secure.
6. With a firm grip on the handle, rotate the crank slowly counterclockwise several complete rotations to clean the chain. If necessary, refill the reservoir with fresh cleaning fluid and continue scrubbing until the chain is clean.
7. Dry the chain thoroughly with a rag to remove all cleaning fluid, and then lubricate the chain.
8. Wipe up spills immediately. Always dispose of cleaning fluid and soiled rags properly.
9. When finished, rinse the Clean Machine with water and allow to air dry.
10. Your Clean Machine will work best if used on a regular basis to prevent hard, caked on grime from accumulating on the chain.



**Performance Tech Support 1(800)727-2453  
9am-6pm EST Monday-Friday**



**Performance, Inc.**  
One Performance Way  
Chapel Hill, N.C. 27514  
Made in Taiwan

[www.performancebike.com](http://www.performancebike.com)

PERFORMANCE and the Flying P Logo are registered marks of Performance, Inc.