

PERFORMANCE

PERFORMANCE

TRAVEL TRAC™
MAG FORCE

**adjustable
magnetic
trainer with
computerized
display**



Performance Tech Support 1(800)727-2453
9am-6pm EST Monday-Friday

Congratulations on your purchase of the Travel Trac™ Mag Force bicycle training system. Your new trainer provides the same data on speed, distance and time that is available from a full-featured cycling computer, plus information on power output (expressed in watts), elevation gain and slope (percent grade). Your indoor training has never been as fun or effective as it will be with your new Travel Trac™ Mag Force!

NOTE: This trainer is intended for single-rider bicycles only.

SAFETY PRECAUTIONS

- Read and follow all instructions.
- Before beginning each workout, be sure bicycle is securely attached to the trainer.
- Do not touch resistance unit during use and for some period after use because it is very hot and can cause burns.
- Keep children and pets away from the trainer during use.
- Before you start any exercise program you should consult a physician.



Performance, Inc.
One Performance Way
Chapel Hill, N.C. 27514
1-800-727-2453
Made in Italy
www.performancebike.com

PERFORMANCE and the Flying P Logo are registered marks of Performance, Inc.

40-1669 0703_1

Table of Contents

I. About Your Travel Trac™ Mag Force System	2
II. Parts List	3
III. Assembly	3
IV. Bicycle Installation	3
V. Set-Up	4
VI. Using Your Travel Trac™ Mag Force Trainer	4
A. Screens	5
B. Battery Life Indicator	6
C. Reset	6
D. Auto Off	6
E. Summary List of Ride Data	6
VII. Troubleshooting	6
VIII. Changing the Batteries	7
IX. Bicycle Removal	7
X. Travel and Storage	7
XI. Specifications	7

Quick-start Instructions (for those who do not like to read instruction manuals)

While the Travel Trac™ Mag Force unit is ready to use right out of the box, please note that the slope and elevation gain information will only be accurate after you have entered your weight in the Set-Up screen. See section V, "Setup", for details.

I. About Your Travel Trac™ Mag Force System

The Travel Trac™ Mag Force system provides a fun, effective workout using your own bicycle in the comfort of your own home, and can easily be switched from bike to bike or between riders. Customize your workout as desired, and get the feedback you need to create a great training program!

Travel Trac™ Trainer Base

The Travel Trac™ Mag Force resistance unit is mounted to a trainer base constructed of heavy-gauge powder-coated steel with rubber, shock-absorbing feet to provide a stable platform for any level of training.

Adjustable Magnetic Resistance Unit

This is a modified version of our popular Mag+ resistance unit, equipped with a handlebar-mounted shift lever and computer console. The adjustable magnetic resistance unit provides a wide range of variable resistance, characterized by smooth, quiet operation. An integrated sensor in the resistance unit sends data to the computer console mounted on your handlebar.

Handlebar-Mounted Shift Lever

The handlebar shift lever allows on-the-fly selection of 5 resistance levels, which simulate slope.

Computer Console

The computer console calculates and displays data provided by the resistance unit sensor. The large LCD screen mounts directly to the handlebar, and presents the data in an easy to read format.

Functions

The Travel Trac™ Mag Force bicycle training system provides the following valuable training feedback:

- Speed:** Current, Average, Maximum
- Distance:** Trip Distance, Total Distance (Odometer)
- Time:** Ride Time, Total Time
- Power:** Current, Average, Maximum
- Slope (% Grade):** Current, Average (Slope is simulated by the level of resistance. Please note that at any given resistance level Slope will vary according to rider weight.)
- Elevation Gain:** Total Elevation Gain, based on Trip Distance and Slope

II. Parts List

Part	Part Code	Quantity
Travel Trac™ Trainer Base.....	A	1
Mag Force Resistance Unit	B	1
Knob Bolt	C	1
Resistance Shift Lever and Cables	D	1
Computer Console	E	1
Pivot Bolt, Washer, Nut	F	1 each
Handle	G	1
Locking Ring	H	1
Axle Support Cups	I	2
Rubber Feet.....	J	4
Rubber Shims for Shift Lever	K	2
"AA" Alkaline Batteries	L	2
Quick Release (QR) Skewer.....	M	1
5mm Hex Wrench	N	1
Cable Clips	O	2

III. Assembly

1. Remove the trainer, resistance unit and all parts from the box. If you believe parts are missing, please contact our Technical Support department for assistance at 1-800-727-2453 from 9am to 6pm, EST Monday – Friday.
2. Use the included 5mm hex wrench and a 13mm box wrench or adjustable wrench to remove the pivot bolt, nut and washer (F) from the frame. See Figures 2A and 2B.
3. Attach the resistance unit (B) to the trainer base (A) using the pivot bolt, washer and nut. See Figure 2C. Tighten to a friction fit—enough that the resistance unit can pivot with some resistance. Position the cable assembly on the left side of the trainer (when viewed from the rear).

IV. Bicycle Installation

⚠ WARNING

Read and follow all instructions concerning installation of the bicycle on the trainer. Failure to securely attach the bicycle to the trainer could result in the bicycle falling, causing injury to the rider or bystanders.

1. Set the Travel Trac™ trainer base on a flat, stable surface.
2. **Note:** Replace the bicycle's rear wheel quick release (QR) skewer with the one provided with the trainer. See bicycle owner's manual for instructions on how to properly adjust the QR skewer. Make sure the QR skewer is tight and not damaged or bent.
3. Loosen the locking ring (H) by rotating it until it contacts the axle support cup. See Figure 3.
4. Spin the handle (G) counterclockwise to fully loosen the right side axle support cup.
5. Loosen the knob bolt (C) by turning it counterclockwise so that the resistance unit is as close to the floor as possible (to provide clearance for the rear wheel).
6. Lift the bicycle into position, so that the rear QR skewer is aligned with the right and left axle support cups (I). See Figure 4.
7. Fit the QR skewer lever on the left side of the wheel into the left axle support cup. Rotate the support cup as necessary, until the notch in the cup is aligned with the QR skewer lever.
8. Tighten the right side axle support cup against the QR skewer nut on the right side of the wheel by spinning the handle clockwise until it contacts the QR skewer nut. Once contact is made, tighten the handle an additional 4-6 rotations.
9. Tighten the locking ring by rotating it until it firmly contacts the trainer base. See Figure 3.

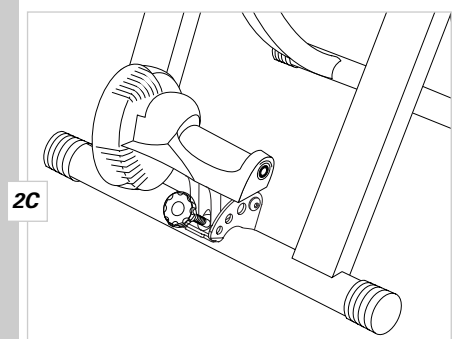
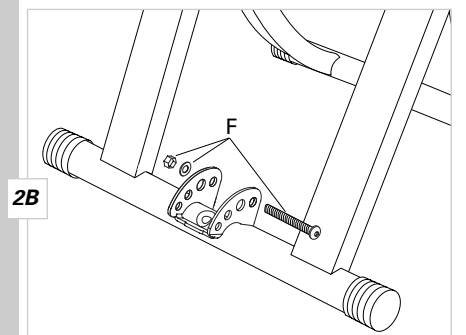
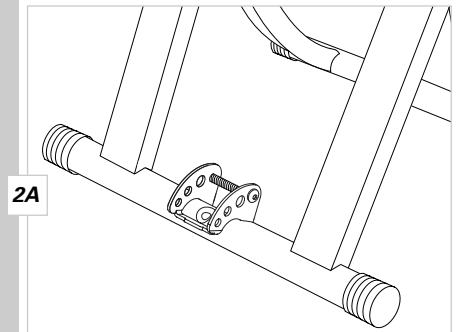
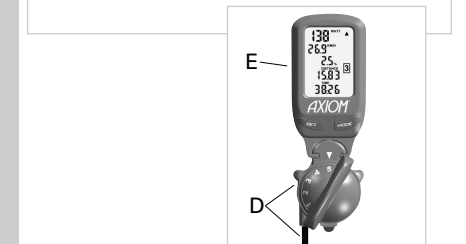
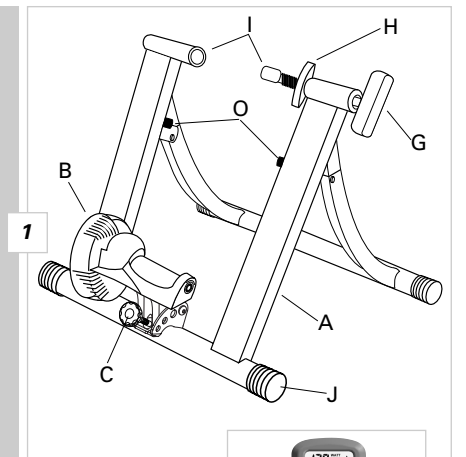

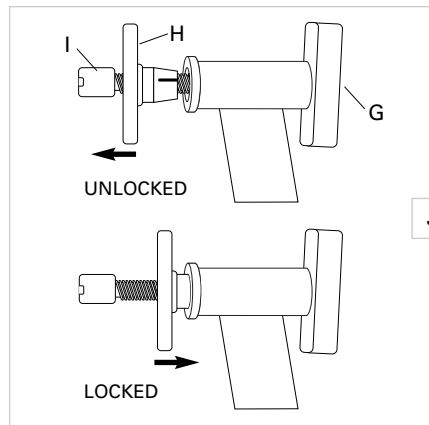

3

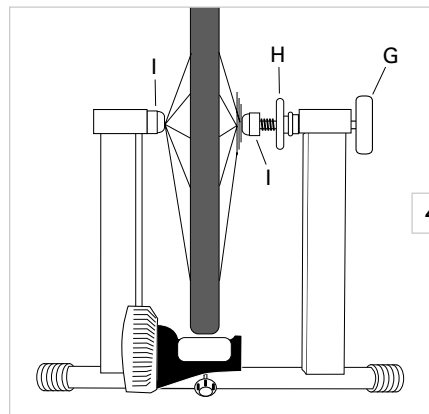

4

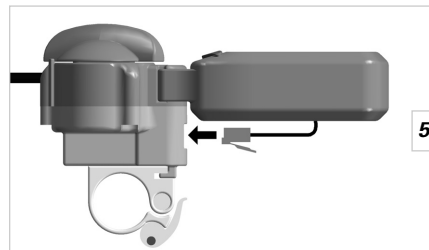

5A

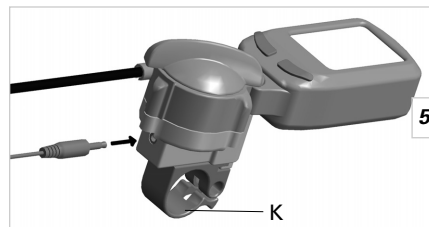

5B

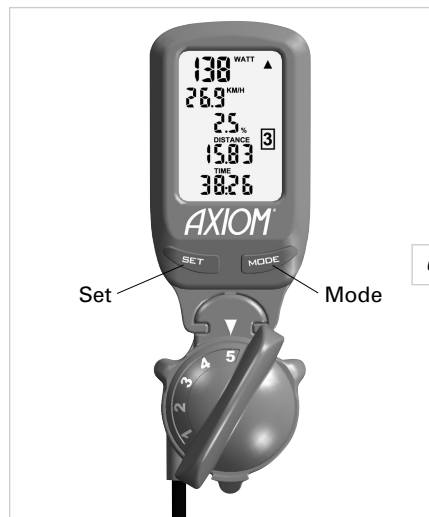

6

- Check that the bicycle is securely installed in the trainer by pushing or pulling on the bicycle's top tube or seat.
- If the bicycle is not secure, check to see that the QR skewer lever and nut are properly positioned in the axle support cups, and that the right side axle support cup is securely tightened.

WARNING
Failure to securely attach the bicycle to the trainer could result in serious injury.

- Install the batteries (L) in the computer console. Remove the battery cover from the underside of the console, install the batteries according to the orientation diagram inside the battery compartment, and replace the cover.
- Attach the resistance shift lever and computer console to the handlebar, preferably close to the stem. Use care to mount the shift lever so that the cable does not interfere with the operation of the bike or the resistance unit. It may be necessary to remove one or both of the rubber shims (K) from the shift lever bracket in order to fit larger diameter handlebars.
- Connect the computer console cable and the resistance unit data cable to the shift lever body. See Figure 5A and 5B.

CAUTION
Make sure that resistance unit cables are clear of all moving bicycles parts.

Tip: To make your indoor workout as quiet as possible, set the trainer on a small section of carpet, and use a rear tire with a smooth tread pattern.

V. Setup

Data generated by the Travel Trac™ Mag Force computer will be accurate only if you first perform the following simple set-up procedure. The set-up screens cannot be accessed while the trainer is in use.

Note: In order to provide accurate data, the weight setting (rider weight + bicycle weight) must be programmed for each user. When switching riders, be sure to program the weight setting (see below).

- To enter the set-up screens, press and hold the right (MODE) button for 4 seconds. See Figure 6.
- Select metric or imperial units of measure. Press the left (SET) button to select between KM/H, Meters and Kilos, or M/H, Feet and Pounds (Lb). See Figure 7. Press the MODE button to enter your selection and proceed to the Weight set-up screen.
- The weight value will appear on the top line of the display screen, with the right digit flashing. See Figure 8. **Note:** This value represents the combined weight of the rider and the bicycle. Enter the combined weight of the rider and bicycle by pressing the SET button to adjust the flashing digit. Press the MODE button to enter your setting and proceed to the next digit. Repeat this process to set the remaining digits. When finished, press the MODE button to enter the value and proceed to the Type set-up screen.
- The correct Type setting for the Travel Trac™ Mag Force is Type 1. See Figure 9. Press the SET button until "type 1" is displayed. Press the MODE button to enter your selection and exit the set-up screens.

VI. Using Your Travel Trac™ Mag Force Trainer

Once the bicycle is mounted to the trainer (see section IV), and the initial set-up is complete (see section V), you are ready to ride.

Press either button (SET or MODE) or begin pedaling to activate the computer. Current Speed and other data should immediately appear in the display screen.

Adjust the resistance level (simulated slope) using the shift lever. Rotating the shift lever from the lowest setting (1) to the highest setting (5) will increase the resistance.

Note: The Slope and Power readings will vary from rider to rider according to the weight value entered in the set-up process (see section V). Therefore, the Slope and Power readings may differ for two riders riding at the same speed and same resistance level settings. The indicated Slope value for each resistance setting is calculated based on the combined rider and bicycle weight.

Note: For accurate Slope, Power and Elevation Gain data, remember to reset the weight value (see section V) when switching between riders on the Travel Trac™ Mag Force.

A. Screens

Three display screens provide various training data as described below. Use the MODE button to scroll between the three screens. All screens can be viewed during a ride.

Screen 1

Displays current values for Power (watts), Speed, Slope, Trip Distance and Ride Time. See Figure 10. Current resistance level setting is indicated on the right side of the display. The ▲▼ speed comparison arrows in the upper right corner of the screen compare current speed to average speed. An upward arrow indicates your current speed is above your average speed. A downward arrow indicates your current speed is below your average speed.

- A. Current Power
- B. Current Speed
- C. Slope
- D. Trip Distance
- E. Ride Time
- F. Resistance Level
- G. Speed Comparison

Screen 2

Displays average values for Power (watts), Speed and Slope. See Figure 11. Also displayed are Trip Distance, Ride Time, resistance level setting and Speed Comparison arrows.

- A. Average Power
- B. Average Speed
- C. Average Slope
- D. Trip Distance
- E. Ride Time
- F. Resistance Level
- G. Speed Comparison

Screen 3

Displays maximum values for Power (watts) and Speed, Elevation Gain, Total Distance (odometer) and Total Ride Time. See Figure 12. Also displayed are resistance level setting and Speed Comparison arrows. The Total Distance and Total Ride Time values represent total distance and time accumulated on all rides to date, and will not be reset when the data screens are cleared (see Section C, "Reset").

- A. Maximum Power
- B. Maximum Speed
- C. Elevation Gain
- D. Total Distance
- E. Total Ride Time
- F. Resistance Level
- G. Speed Comparison



7

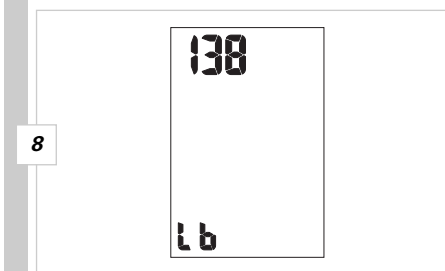

8

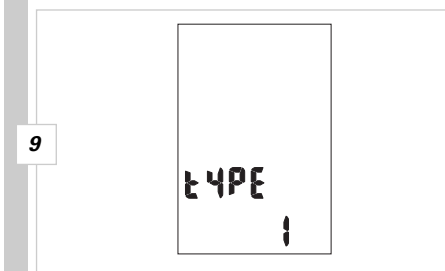

9

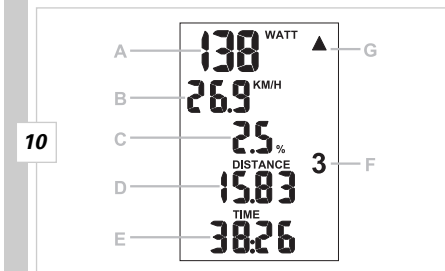

10

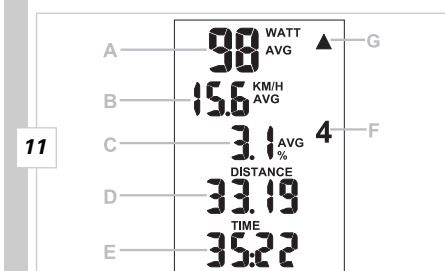

11

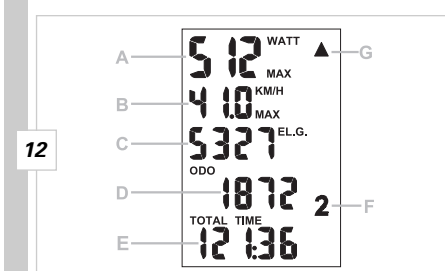

12

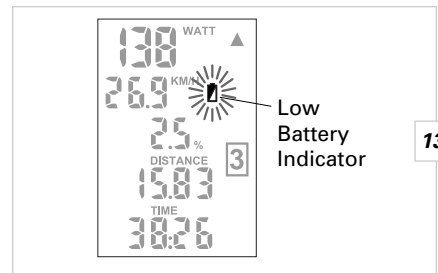

Low Battery Indicator

13

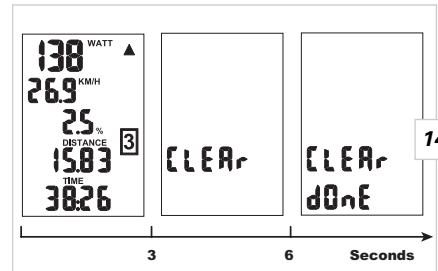

14

B. Battery Life Indicator

When battery life is low, a battery icon will flash in the display screen to indicate only a few hours of battery life remain. See Figure 13. When the battery icon appears, replace the batteries as soon as possible.

C. Reset

At the beginning of each ride you'll want to perform a reset to clear from memory the data from your previous ride.

- To clear the data, press and hold the SET button. After 3 seconds, "CLEAR" will be displayed (at this point no data has been deleted). Continue to hold the SET button and in another 3 seconds "DONE" will appear, indicating that all accumulated data (except Total Distance and Total Ride Time) has been cleared from memory. See Figure 14.
- To reset Total Distance and Total Ride Time (as well as all other data), press and hold both the SET and MODE buttons. After 8 seconds "CLEAR" will be displayed (at this point no data has been deleted). Continue to hold the SET and MODE buttons, and in another 2 seconds "DONE" will appear, indicating that all accumulated data has been cleared from memory.

D. Auto Off

After 2 minutes of inactivity (no pedaling or button presses) the system will automatically switch off to prolong battery life. Current values will be maintained. To turn the system back on press either button (SET or MODE) or begin pedaling.

E. Summary List of Ride Data

SYMBOL	SCREEN	INFO
WATT	1	Current Power
km/h- M/H	1	Current Speed
%	1	Slope (% Grade): A function of the resistance level and the rider + bike weight
DST	1-2	Trip Distance: Distance accumulated during current ride (or since last reset)
TIME	1-2	Ride Time: Time accumulated during current ride (or since last reset)
①②③④⑤	1-2-3	Indicates Resistance Level (1-5)
▲▼	1-2-3	Speed Comparison: Indicates whether current speed is above or below average speed
AVG WATT	2	Average Power developed for current ride (or since last reset)
AVG km/h-M/H	2	Average Speed for current ride (or since last reset)
% AVG	2	Average Slope for current ride (or since last reset)
MAX WATT	3	Maximum Power: Indicates maximum wattage attained during current ride (or since last reset)
MAX Km/h	3	Maximum Speed: Indicates highest speed attained during current ride (or since last reset)
ELV.G	3	Elevation Gain: Indicates total elevation climbed during current ride (or since last reset)
ODO	3	Total Distance: Indicates total distance accumulated on all rides to date.
TOTAL TIME	3	Total Ride Time: Indicates total ride time accumulated on all rides to date.
⚡	3	Low Battery Indicator: Indicates batteries should be replaced

VII. Troubleshooting

- Display not working**
 - Check cable connections to the computer console.
 - Replace the batteries in the computer console. See section VIII, "Changing the Batteries."
- Resistance level indicator stays on level 1**
 - Check cable connection between the computer console and the shift lever.
- Data Values Erratic**
 - Check cable connections to the computer console.
 - Replace the batteries in the computer console. See section VIII, "Changing the Batteries."
- Low Battery Indicator Appears**
 - Replace the batteries in the computer console. See section VIII, "Changing the Batteries."

Note: The resistance unit and the computer console contain no user-serviceable parts. The warranty is void if either unit has been opened.

VIII. Changing the Batteries

The computer console uses 2 "AA" batteries. When the low battery life indicator appears in the display, or if the display is erratic, faint or disappears altogether, new batteries are needed.

- To replace the batteries, remove the battery cover from the underside of the computer console.
- Remove the used batteries and dispose of properly.
- Install fresh batteries according to the orientation diagram inside the battery compartment, and replace the cover.

Note: During a battery change, current data and set-up values will be retained in memory.

IX. Bicycle Removal

- Remove the shift lever assembly from the handlebar.
- Loosen the knob bolt (C) so that the resistance unit is as close to the floor as possible.
- Loosen the locking ring (H) by rotating it until it contacts the axle support cup (I). See Figure 3.
- While supporting the bicycle, loosen the right side axle support cup by spinning the handle (G) counterclockwise, until the rear wheel axle is free of the support cups.
- Note:** The QR skewer provided with the trainer can be used when riding the bicycle off the trainer as well. If you choose to reinstall your bicycle's original skewer, refer to your bicycle owner's manual for instructions on properly adjusting the skewer. Before riding, ensure the quick release skewer is tight.

X. Travel and Storage

- To keep the shift lever cable out of the way during transport or storage, coil the cable and tuck it behind the cable clips (O) on the trainer frame. See Figure 15.
- Grasp the trainer frame by the handle and lift. Fold the legs together, and the trainer is ready for transport or storage. Be careful when folding the legs to avoid pinching your fingers.

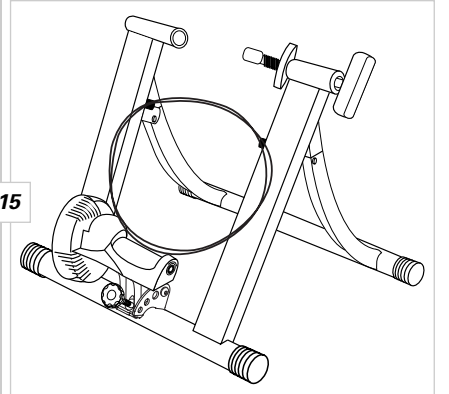

15

XI. Specifications

Battery Type: 2 "AA" Alkaline Cells

Battery Life: Approximately 300 hours

Computer Data Fields:

Power (watts): up to 999 watts

Speed: up to 99.9 miles/hour or 99.9 kilometers/hour

Distance: up to 999.99 miles or kilometers

Odometer: up to 99999 miles or kilometers

Ride Time: up to 9 hours, 99 minutes, 59 seconds

Total Time: up to 999 hours, 59 minutes

Elevation Gain: up to 9999 feet or meters

Weight Input Field: up to 330 pounds or 150 kilograms

Units of Measurement:

Metric: Distance in Kilometers, Elevation in Meters, Weight in Kilograms, Speed in Kilometers/Hour

Imperial: Distance in Miles, Elevation in Feet, Weight in Pounds, Speed in Miles/Hour