

Performance Side Show 4 Bike Rack Box Sticker  
02\_26\_04  
Art @100%  
Magenta Key lines don't print

1. pms 2935 2. pms 2935-70% 3. 100% blk

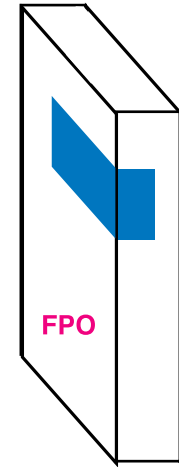

## 4 bike hitch rack

- Proprietary swing-away technology provides quick, complete access to rear of vehicle with fully loaded rack
- Rock solid design carries up to 4 bikes
- Advanced cradles allow independent adjustment for each bike
- Unique anti-sway bars fit any frame design, or can be removed completely
- Ratcheting, padded straps secure bikes
- Rubber cradles protect frame finish
- Integrated cable lock and locking hitch foot
- Fits any standard 2" receiver hitch

**PERFORMANCE**<sup>®</sup>

FOR PEOPLE WHO LOVE BIKES<sup>™</sup>

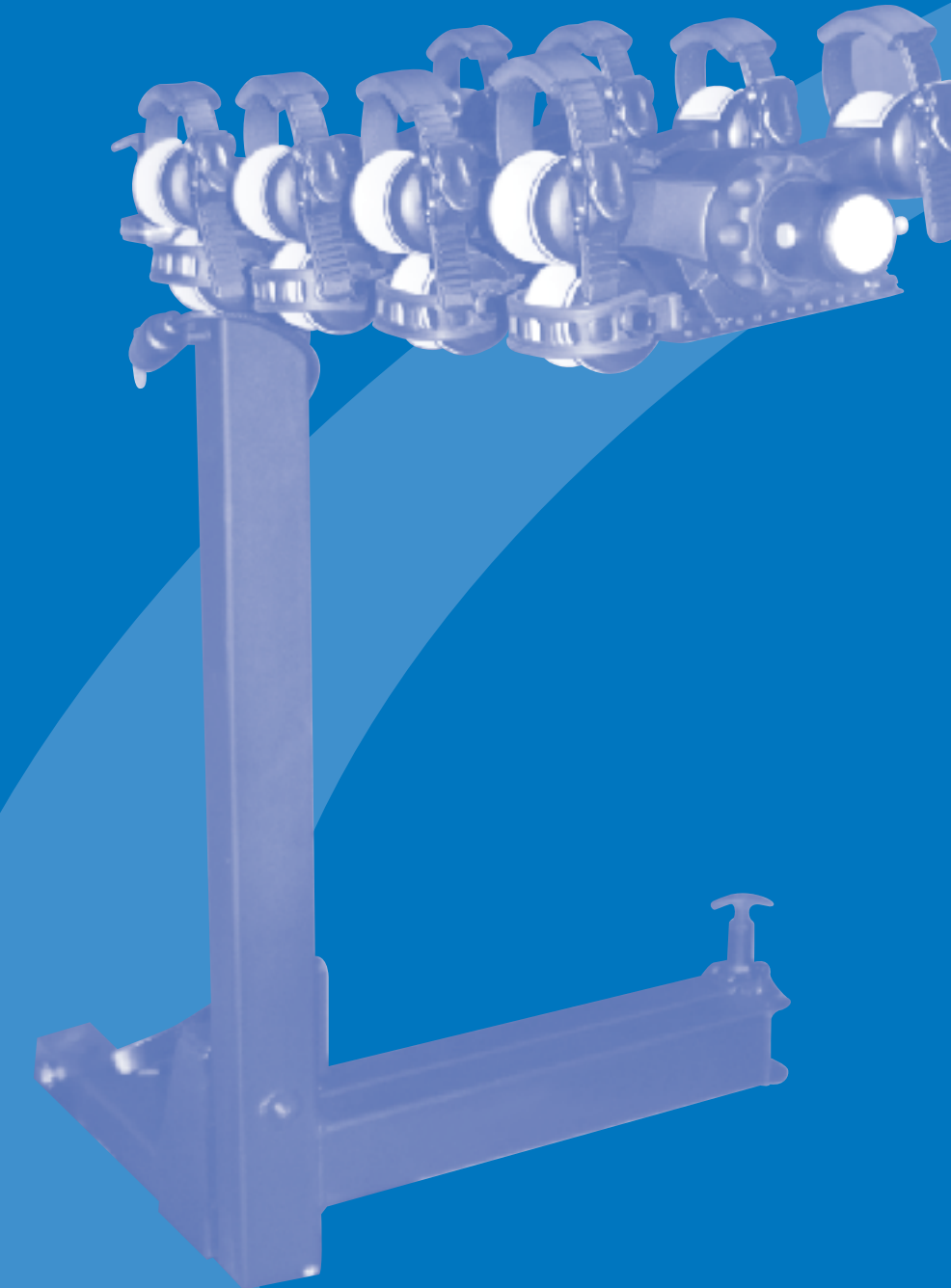

## 4 bike hitch rack

Performance Inc.  
One Performance Way  
Chapel Hill, NC 27514  
Made in Taiwan  
PerformanceBike.com  
PERFORMANCE and the Flying P are  
registered marks of Performance Inc.



**PERFORMANCE<sup>®</sup>**

**Performance Tech Support 1(800)553-8324  
9am-6pm EST Monday-Friday**



**Performance, Inc.**  
One Performance Way  
Chapel Hill, N.C. 27514  
Made in Taiwan  
[www.performancebike.com](http://www.performancebike.com)

PERFORMANCE and the Flying P Logo are registered marks of Performance, Inc.

40-1974 0504\_1

**PERFORMANCE<sup>®</sup>**

**XPORT**



# 4-bike hitch rack



***Congratulations on your purchase of an XPORT™ Side Show hitch rack. This rack will securely carry up to 4 bicycles, and swings away from the vehicle a full 180° to allow convenient access to the rear of the vehicle. Please read these instructions thoroughly before using your new hitch rack.***

**CAUTION**

IT IS THE USER'S RESPONSIBILITY TO ENSURE THE SAFE AND PROPER USE OF THIS PRODUCT. Improper attachment or misuse of this product may result in personal injury and serious damage to the bicycles, the hitch rack, your vehicle or vehicles following behind you on the road.



**Minimum Hitch Requirement:** Class III receiver hitch, bolted to the vehicle chassis



**Maximum Bicycle Limit:** 4 bicycles



**Maximum Load Limit:** 175 lb MAX

**CAUTION**

Do not exceed maximum bicycle limit or maximum load limit listed in this owner's manual. Combined weight of rack and bicycles must not exceed vehicle or receiver hitch maximum tongue weight.

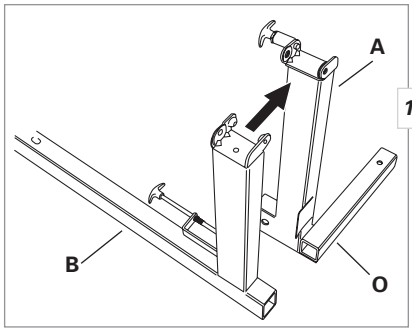

1A

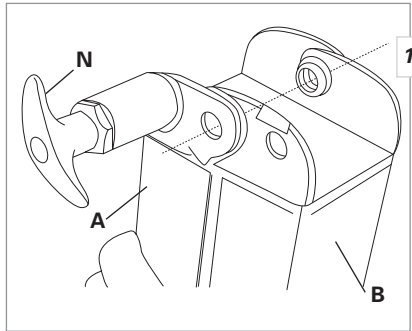

1B

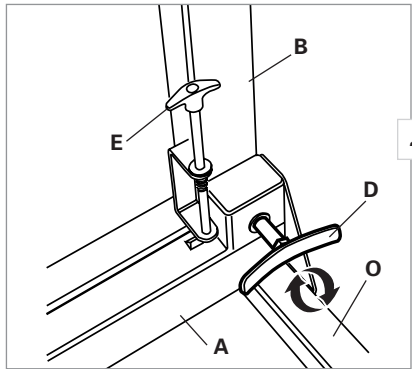

2

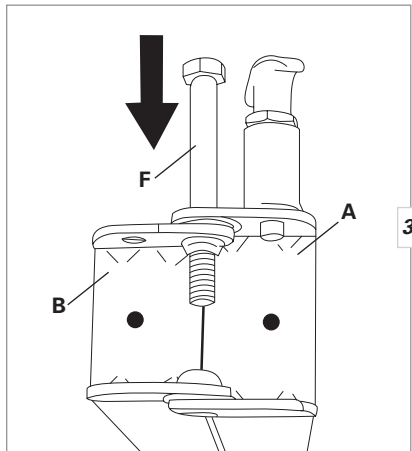

3A

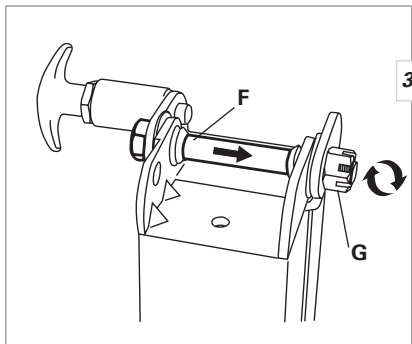

3B

## I. Parts List

Part	Part Code	Quantity
Stationary Frame Tube	A	1
Swinging Frame Tube	B	1
Carrier Head Tube	C	1
Threaded T Bolt	D	1
Spring Loaded T Bolt	E	1
Hinge Bolt, Nut and Cotter Pin	F, G, H	1 each
Pivot Plates	I	2
Pivot Plate T Bolt	J	1
Pivot Plate Bolts, Nuts, Washers	K, L, M	2 each
Pivot Hinge T Bolt	N	1
Hitch Tube	O	1
Cradle Assembly	P, Q, R, S, T	4 each
Rubber Cradle Pads	U	8
Cradle Straps and Buckles	V, W	8 each
Anti-sway Bars, Straps and Release Buttons	X, Y, Z	4 each
Threaded Insert, Hitch Bolt, Washer and Lock	AA, BB, CC, DD	1 each
Cable Lock	EE	1
Lock Post and Securing Clip	FF, GG	1 each

## II. Assembly

### Assembling the Frame

1. Remove the rack and all other contents from the box.
2. Place the stationary frame tube (A) and swinging frame tube (B) on the floor or a worktable.
3. Slide the hinged ends of the frame pieces together so the bolt holes are aligned. See Figure 1A and 1B.
4. Insert the threaded T bolt (D) through the stationary frame tube and thread it loosely into the swinging frame tube to hold the two pieces together—this will simplify the assembly. See Figure 2. Do not fully tighten the T bolt at this time.
5. Locate the hinge bolt hardware (F), (G), (H). Tap the hinge bolt (F) through the bolt holes in the frame tube hinge. See Figure 3A. Thread the nut (G) onto the bolt until the end of the bolt is flush with the nut and the cotter pin hole in the end of the bolt is visible. See Figure 3B.
6. Insert the cotter pin (H) all the way through the hole in the bolt, and use a pair of pliers to spread the ends of the cotter pin so it cannot slide out. See Figure 4A and 4B. This will prevent the nut from loosening, but will allow enough play for the swinging frame to open and close easily.
7. The carrier head tube (C) has been installed for shipping in a position that is not functional for rack use. It must be rotated 90° to its correct position.
8. Use the provided 6mm hex wrench and an adjustable wrench to loosen and remove the pivot plate bolts (K) nuts (L) and washers (M). See Figure 5. Rotate the carrier head 90° so that it points away from the rear of the vehicle—in the opposite direction from the hitch tube (O). See Figure 6. Reinstall the pivot bolts and nuts. Make sure the washer (M) is between the nut and the under side of the pivot plate (I).

**NOTE:** Do not overtighten the pivot plate bolts (K). When tightened properly, there should be enough play between the upper and lower pivot plates (I) to allow them to pivot with mild resistance.

### Attaching the Bike Cradles

1. Attach the bike cradles (P) one by one to the carrier head tube (C).
2. Slide the plastic hub (Q) onto the tube. See Figure 7A. Align the hub with the bolt hole in the carrier head tube and secure it with one bolt (R) and nut (S).
3. Slide the bike cradle (P) onto the tube and over the plastic hub. See Figure 7B. Make sure the teeth on the hub and cradle are aligned.
4. Slide the locking collar (T) onto the tube and thread it snugly onto the plastic hub. See Figure 7C.
5. Install the remaining three bike cradles in the same way.

### Inserting the Lock Post

1. Insert the lock post (FF) through the hole in the end of the carrier head tube (C). See Figure 8A.
2. Press the securing clip (GG) onto the lock post to secure it in place. See Figure 8B.

### Installing the Hitch Rack

1. Slide the threaded insert (AA) into the end of the hitch tube (O) and align the bolt holes. See Figure 9.
2. Slide the hitch tube into the vehicle receiver hitch.
3. Align the bolt hole in the vehicle receiver hitch with the bolt holes in the hitch tube and threaded insert. Slide the washer (CC) onto the hitch bolt (BB), thread the bolt through the receiver hitch and tighten securely. See Figure 10.
4. Press the lock (DD) onto the end of the hitch bolt (BB) and turn the key to lock it in place. See Figure 11.

## III. Using the Hitch Rack

### Adjusting Cradles

1. Adjust the angle of each bike cradle (P) to best accommodate the size and geometry of each bicycle frame. Loosen the locking collar (T), pull the cradle toward you to disengage the teeth and rotate the cradle to a suitable position.
2. Once the cradle is in the desired position, push it against the plastic hub (Q) to engage the teeth, and retighten the locking collar securely.

### Adjusting and Securing Anti-sway Bars

1. The anti-sway bars (X) can be adjusted in several ways to stabilize each bicycle and prevent bike contact during transport.
2. Adjust the anti-sway bar so it can be secured to the bicycle frame's down tube or seat tube.
3. To extend or retract the anti-sway bar, press the gray release button (Z) and slide the bar left or right to the desired position. See Figure 12A. The bar can also be removed completely and reinserted from either side of the cradle, in its original orientation or flipped 180°. See Figure 12B.
4. To accommodate some frames—particularly those with small main triangles—the anti-sway bar may have to be removed completely and not used. In this case, you may wish to use straps, bungee cords or some other means to prevent bike contact.
5. Once the anti-sway bar is positioned with its rubber pad firmly against the bicycle frame's down tube or seat tube, wrap the anti-sway strap (Y) around the bicycle frame tube and secure it to the anti-sway bar. See Figure 13.

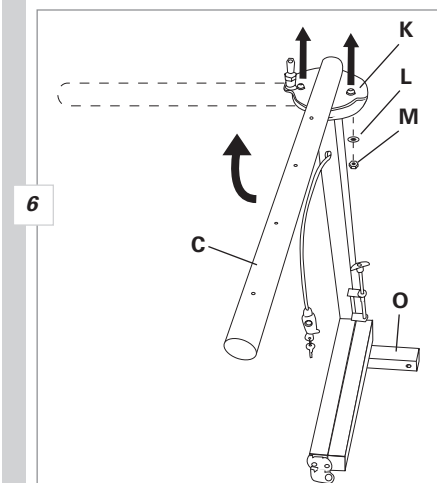
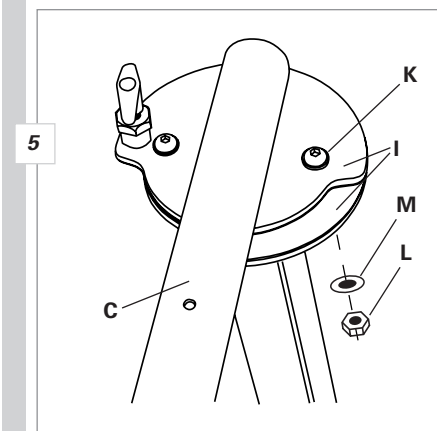
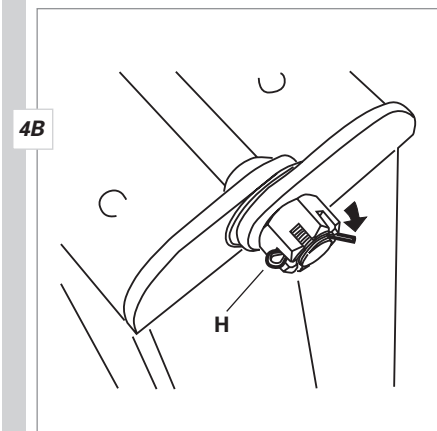
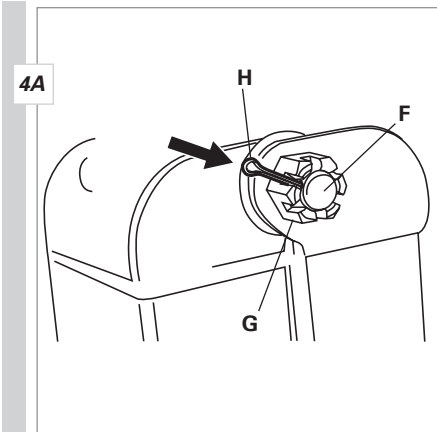

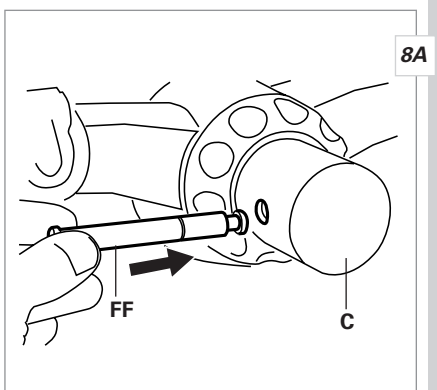
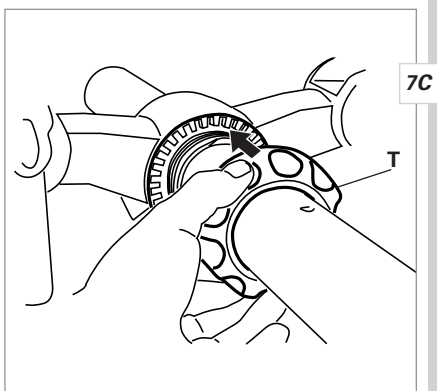
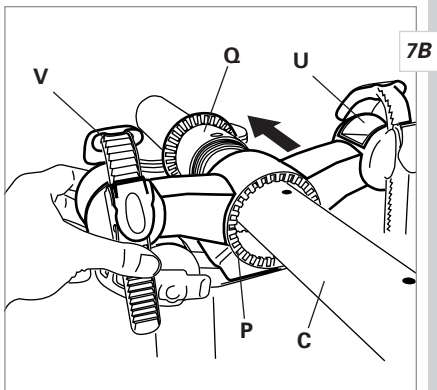
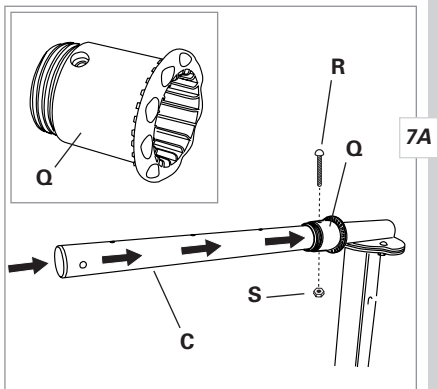

### Loading Bicycles

1. To make sure each bicycle is securely attached to the rack, load and completely secure one bicycle at a time, beginning with the largest bike. Make sure the bicycle is balanced in the cradle (with the frame contacting both cradle pads) and that the wheels are as close to parallel with the ground as possible. If necessary, make further adjustments to the angle of the cradle. See "Adjusting Cradles".
2. Secure the bicycle to the cradle with the cradle straps (V). Pass the cradle strap over the bicycle frame tube, feed the loose end of the strap into the ratcheting buckle (W), and tighten securely. See Figure 13.
3. Stabilize the bicycle with the anti-sway bar. See "Adjusting and Securing Anti-sway Bars".
4. Load all additional bicycles, alternately facing the handlebars to the left or right so that alternating bikes face in opposite directions.

**NOTE:** Once loaded, all bikes should be balanced in a way that allows secure attachment to the rack. The bicycle frame should contact both cradle pads firmly, and the wheels of each bike should be as close to parallel with the ground as possible. This rack will accommodate many, but not ALL frame designs and sizes. Some frames with small main triangles—such as compact women's frames and some dual suspension frames — may require a top tube frame adapter (such as 40-1804) for secure attachment. Other frames may not fit at all in a way that allows them to be safely transported on this rack.

### CAUTION

Do not transport a bicycle which cannot be securely attached to the rack.

### Locking Bikes

1. Once the bicycles are loaded, secure them with the integrated cable lock (EE).
2. Pass the head of the cable lock through the bicycle frames (and around the last frame on the rack), and secure it to the cable lock post (FF) at the end of the carrier head tube. See Figure 13.
3. When there are no bicycles on the rack, attach the cable lock to the lock post at the top of the swinging frame tube (B).
4. Keep in mind that locks deter theft but cannot guarantee the security of your bicycles or hitch rack.

### Using the Swing Away Feature

#### To Open

1. The XPORT™ Side Show rack swings away from the vehicle a full 180° to allow easy access to the rear of the vehicle. At the same time, the carrier head tube (C) pivots 90° in the opposite direction to prevent contact between the bikes and vehicle.
2. Loosen the threaded T bolt (D) at the base of the stationary frame (A). See Figure 14A. It is not necessary to remove the T bolt, just loosen it until the threads are no longer engaged.
3. Lift the spring loaded T bolt (E) about ½" to release the swinging frame (B), and pivot the swinging frame toward the right side of the vehicle (from the driver's perspective). See Figure 14A. The T bolt spring tension is tight, and will require moderate force to release.
4. As you begin to swing the rack open, loosen the pivot plate T bolt (J) by turning it counterclockwise until the threads are no longer engaged. See Figure 14B.
5. Lift the pivot plate T bolt (J) and pivot the carrier head tube (C) to the left as you continue to open the rack. When the carrier head tube is fully open (90° from its starting position) the T bolt (J) will pop into a hole in the pivot plate to lock the carrier head in the open position.
6. When the swinging frame (B) is fully open (180° from its starting position) the pivot hinge T bolt (N) will pop into a hole to lock the rack into the open position and prevent it from accidentally swinging shut.

### To Close

1. Lift the pivot hinge T bolt (N) to release the swinging frame, and pivot the rack toward the rear of the vehicle. See Figure 15A.
2. As you close the rack, lift the pivot plate T bolt (J) to release the carrier head tube (C) and return it to its original position. See Figure 15B. Make sure the pivot plate T bolt (J) pops into the hole in the pivot plate to secure the carrier head tube in the closed position, and tighten the T bolt (J) securely by turning it clockwise until it is tight.
3. Lift the spring loaded T bolt (E) and push the swinging frame (B) against the stationary frame (A) to close the rack. See Figure 15A. Pull on the swinging frame to make sure it is latched securely.
4. Tighten the threaded T bolt (D) securely. See Figure 15A. This bolt should ALWAYS be securely tightened when the rack is closed.

### For Parking

1. To simplify parking and maneuvering when there are no bikes on the rack, the carrier head tube can be pivoted 90° to the left (driver's side).
2. Loosen the pivot plate T bolt (J) by turning it counterclockwise until the threads are no longer engaged.
3. Lift the pivot plate T bolt (J) and pivot the carrier head 90° to the left until the T bolt (J) pops into the hole in the pivot plate to lock the tube in position.
4. Tighten the T bolt (J) securely by turning it clockwise until it is tight.

### CAUTION

#### FOR SAFE AND PROPER USE OF YOUR HITCH RACK:

1. Keep bicycle tires clear of the exhaust pipe. Hot exhaust can melt or burn bicycle tires.
2. Inspect your hitch rack before each use, both before and after loading bicycles. Ensure all bolts, knobs, clevis pins and pin clips are installed properly and tightened securely.
3. Check the security of all bikes at regular intervals during use, more frequently on bumpy roads, and immediately if the bicycles shift position.
4. Never exceed the maximum bicycle limit or load limit listed in this owner's manual or vehicle or receiver hitch maximum tongue weight.
5. Do not use any portion of the rack frame as a step to access vehicle roof.
6. Do not attach this rack to a trailer or to a vehicle being towed by another vehicle.
7. Reduce speed when driving on rough or unsurfaced roads.
8. Do not use a 1¼" to 2" adapter to install this rack in a 1¼" receiver hitch.
9. Remove the hitch rack from vehicle when not in use.

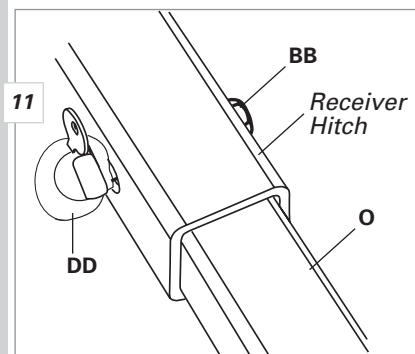
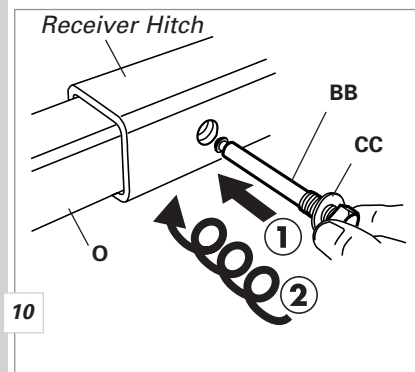
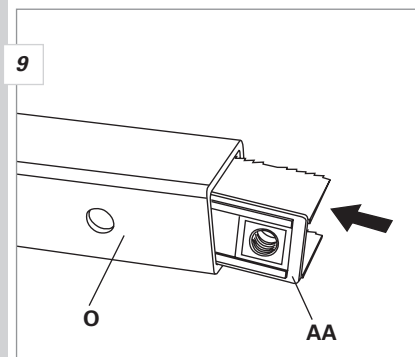
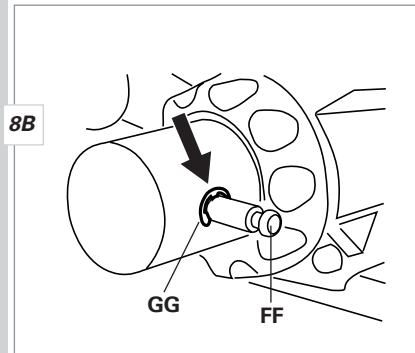

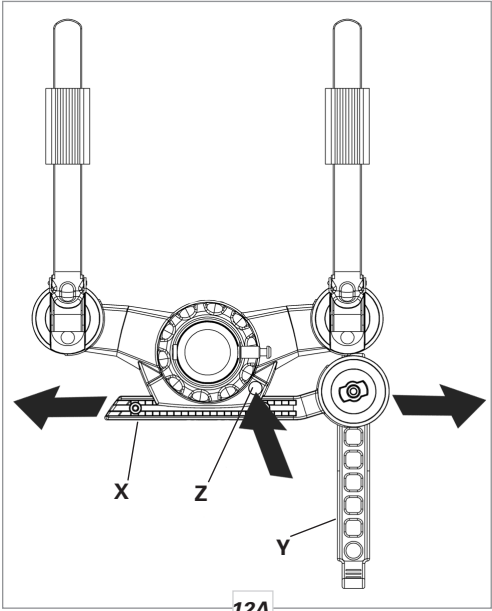

12A

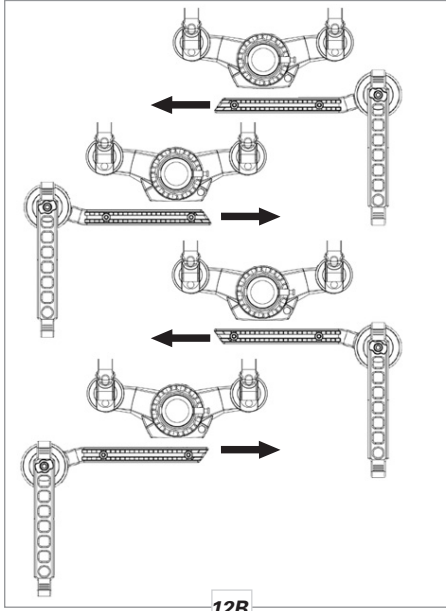

12B

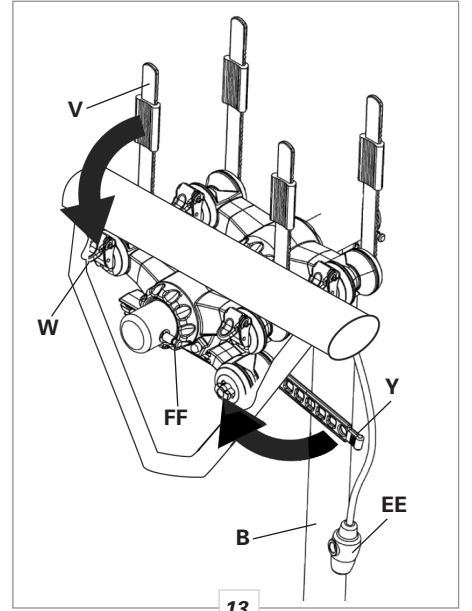

13

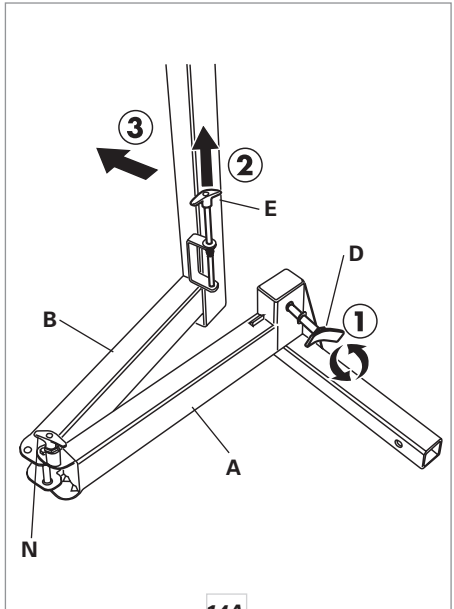

14A

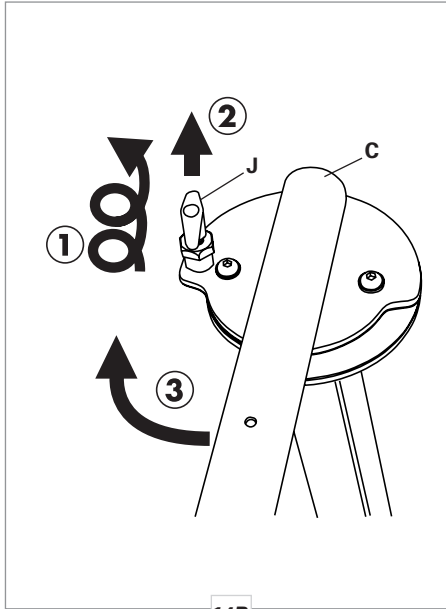

14B

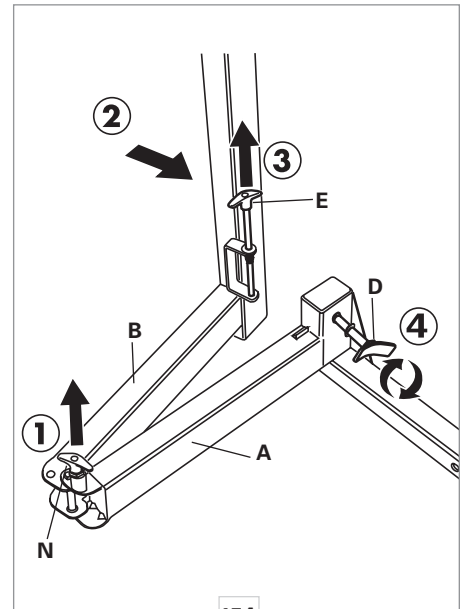

15A

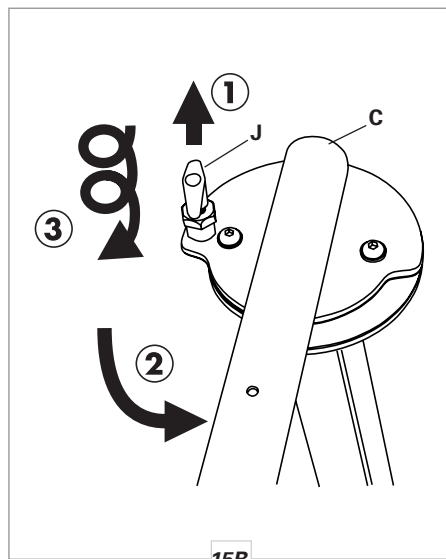

15B

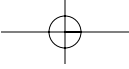

NOTES.....

