

PERFORMANCE®

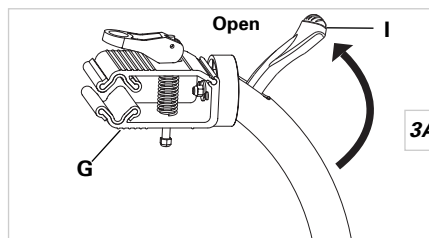

3A

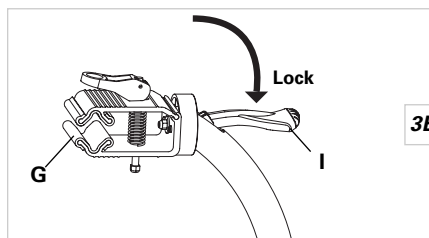

3B

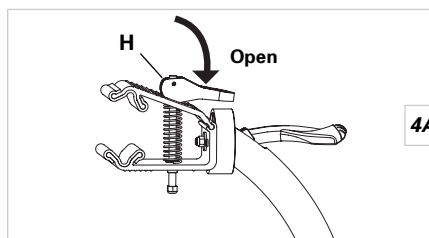

4A

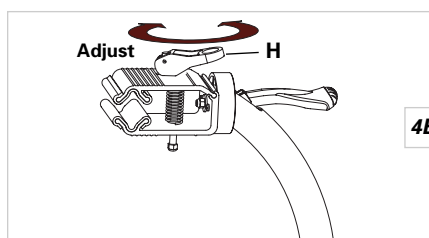

4B

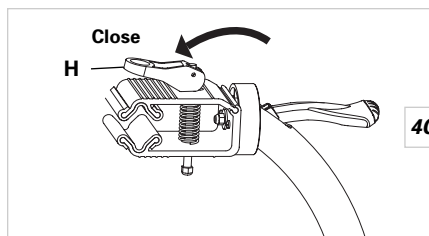

4C

III. Using the Workstand

1. Set the Team Repair Stand on a flat, stable surface.
2. Raise or lower the sliding tube (B) to the desired height by loosening the locking handle (C), adjusting the tube height and re-tightening the handle. See Figure 2. Height adjustments should be made *without* a bicycle in the stand.
3. To rotate the jaw clamp (G), open the clamp rotation lever (I), rotate the jaw clamp to the desired position, and lock the rotation lever. See Figure 3A and 3B. This adjustment can be made with or without a bicycle in the stand.
4. Flip the jaw clamp quick release lever (H) to the OPEN position. See Figure 4A.
5. Place your bicycle in the jaw clamp (G) and flip the quick release lever to the CLOSED position. See Figure 4C.

NOTE: To avoid possible frame damage, it is always best to clamp the bicycle by the seat post rather than the top tube or seat tube. If you must clamp the top tube or seat tube use minimal clamp pressure to avoid damaging the frame.

6. If the jaw clamp is too difficult to close, or if it closes too easily and does not clamp the bicycle securely, the jaw clamp tension should be adjusted. Flip the quick release lever (H) to the OPEN position, and spin it clockwise to tighten or counterclockwise to loosen the clamping tension. See Figure 4B. Then close the lever and re-check clamping tension. Repeat this process until the bicycle is securely clamped in the stand.
7. To store or transport the Team Repair Stand, loosen the locking handle (C), lower the sliding tube (B) and re-tighten the locking handle. Open the tube collar quick release lever (E) and fold the legs, securing them in the brackets on the tube collar (D). See Figure 5. Close the tube collar quick release lever.

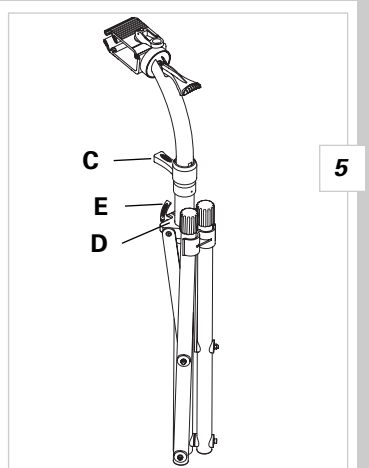

5

Performance Tech Support 1(800)553-8324
9am-6pm EST Monday-Friday



Performance, Inc.
One Performance Way
Chapel Hill, N.C. 27514
Made in China
www.performancebike.com

PERFORMANCE and the Flying P Logo are registered marks of Performance, Inc.

40-1993 0404_1