

**PERFORMANCE<sup>®</sup>**

# SPIN DOCTOR<sup>™</sup> PRO G2

## repair stand

*Thank you for your purchase of the Spin Doctor<sup>™</sup> Pro G2 Repair Stand. The wide, stable base, adjustable height and 360° rotating jaw clamp make working on any bike easier, while the compact folded size make transport and storage simple.*



### I. Parts List

Part	Part Code	Quantity
Base Tube	A	1
Sliding Tube	B	1
Lower Tube Collar	C	1
Lower Tube Collar Quick Release Lever	D	1
Legs	E	2
Upper Tube Collar	F	1
Upper Tube Collar Quick Release Lever	G	1
Jaw Clamp	H	1
Clamp Knob	I	1
Clamp Rotation Lever	J	1
Clamp Lever	K	1
Clamp Adjust Knob	L	1

### II. Assembly

1. The Pro G2 Repair Stand comes fully assembled and takes only a minute to open and begin using.
2. Open the lower tube collar quick release lever (D), unfold the legs (E) completely, and close the quick release lever securely. See Figure 1.

**Note:** When unfolding the legs, keep hands clear of moving parts to avoid pinched fingers.

3. Loosen the upper tube collar quick release lever (G), raise the sliding tube (B) to a suitable height and close the quick release lever securely. See Figure 2A and Figure 2B.

**Note:** In the closed position the quick release lever should be flush with the tube collar to prevent accidental release while using the stand. See Figure 2C.

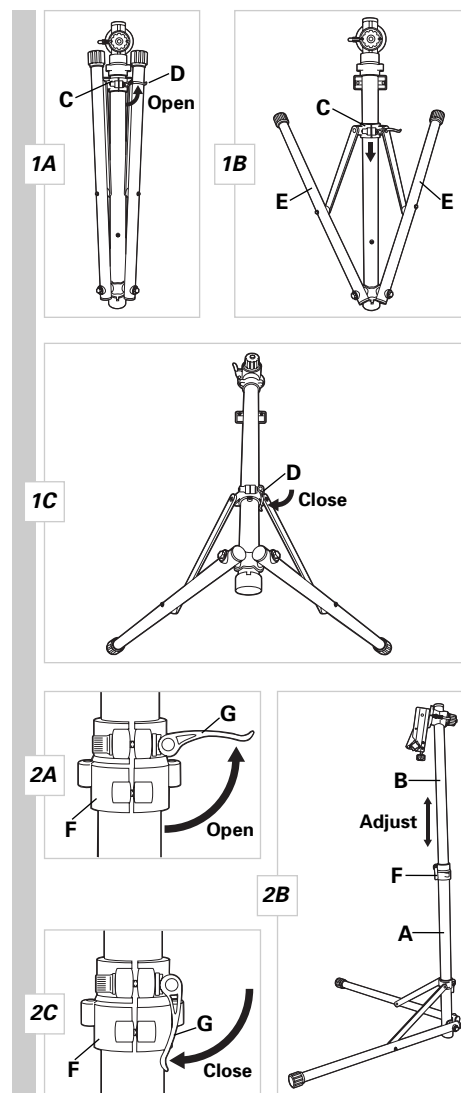

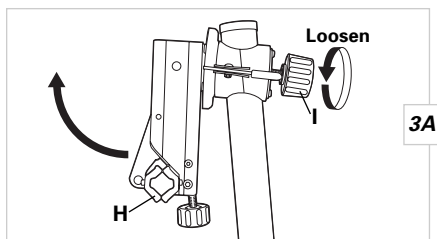

3A

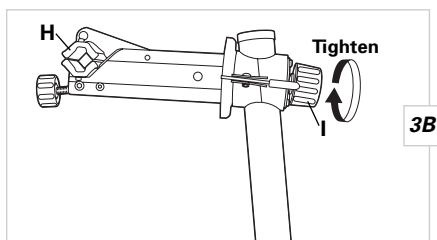

3B

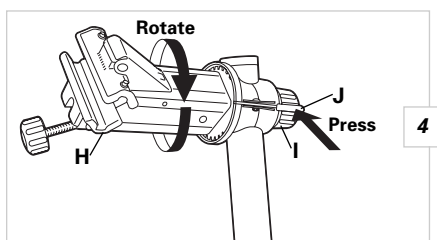

4

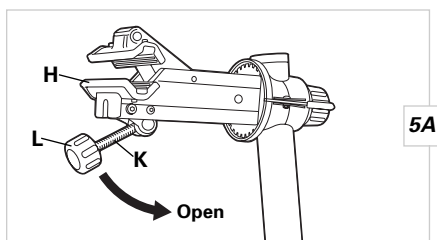

5A

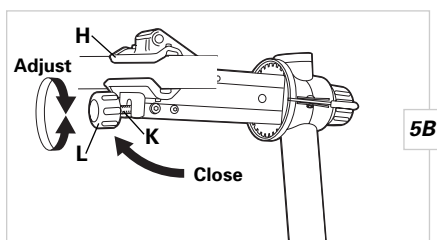

5B

- Loosen the clamp knob (I) completely, raise the jaw clamp (H) and push it toward the stand to align it with the square metal bracket. Keep fingers clear to avoid pinching between the jaw clamp and metal bracket. Tighten the clamp knob (I) firmly to secure the jaw clamp in position. See Figure 3A and Figure 3B.

### III. Using the Workstand

- Set the Pro G2 Repair Stand on a flat, stable surface.
- Raise or lower the sliding tube (B) to the desired height by loosening the upper tube collar quick release lever (G), adjusting the tube height and closing the quick release lever. See Figure 2.

**Note:** It is recommended that all height adjustments be made *without* a bicycle in the stand.

- The jaw clamp (H) can be rotated to position the bicycle as desired. Loosen the clamp knob (I) slightly, depress the clamp rotation lever (J) and rotate the jaw clamp. Release the rotation lever when the jaw clamp is in the desired position and tighten the clamp knob (I) firmly. See Figure 4. This adjustment can be made with or without a bicycle in the stand.
- Push the clamp lever (K) down to open the jaw clamp (H). See Figure 5A.
- Place your bicycle in the jaw clamp and pull the clamp lever up to close the jaw clamp. See Figure 5B.

**Note:** To avoid possible frame damage, it is always best to clamp the bicycle by the seat post rather than the top tube or seat tube. If you must clamp the top tube or seat tube use minimal clamp pressure to avoid damaging the frame.

- If the jaw clamp is too difficult to close, or if it closes too easily and does not clamp the bicycle securely, turn the clamp adjust knob (L) clockwise to increase clamping tension or counterclockwise to loosen clamping tension. See Figure 5B.
- To store or transport the Pro G2 Repair Stand, loosen the upper tube collar quick release lever (G), lower the sliding tube (B) and close the quick release lever. Loosen the clamp knob (I) completely, pull the jaw clamp (H) away from the stand, fold it against the sliding tube and retighten the clamp knob. Open the lower tube collar quick release lever (D), fold the legs against the base tube (A), and close the quick release lever.

### IV. Accessories

The optional Spin Doctor™ tool tray (40-1586, available separately) attaches easily to the Pro G2 Repair Stand to keep tools and small parts close at hand during repairs.

Performance Tech Support 1(800)553-8324  
9am-6pm EST Monday-Friday



Performance, Inc.  
One Performance Way  
Chapel Hill, N.C. 27514  
Made in Japan  
www.performancebike.com

PERFORMANCE and the Flying P Logo are registered marks of Performance, Inc.