

SPIN DOCTOR PRO G3

repair stand

Thank you for your purchase of a Spin Doctor™ PRO G3 Repair Stand. The stable tripod base, adjustable height and 360° rotating clamp make working on any bike easier, while the compact folded size simplifies storage.

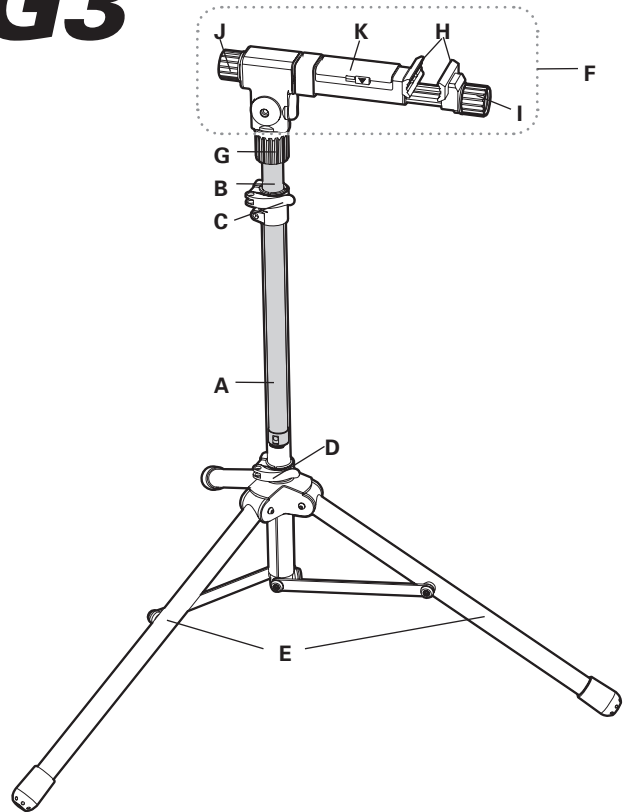

I. Parts List

| Part | Part Code | Quantity |
|---------------------------------|-----------|----------|
| Base Tube | A..... | 1 |
| Sliding Tube | B..... | 1 |
| Height Adjustment QR Lever..... | C..... | 1 |
| Tripod Base QR Lever..... | D..... | 1 |
| Legs | E..... | 3 |
| Clamp Arm | F..... | 1 |
| Clamp Arm Securing Knob | G..... | 1 |
| Clamp Jaws..... | H..... | 2 |
| Clamp Adjusting Knob..... | I..... | 1 |
| Clamp Rotation Knob..... | J..... | 1 |
| Small Parts Box | K..... | 1 |

II. Assembly

1. The PRO G3 Repair Stand comes fully assembled and takes only a minute to open and begin using.
2. Open the tripod base QR lever (D), unfold the legs (E) completely, and close the QR lever securely. *See Figure 1A, 1B, 1C.*
3. Loosen the clamp arm securing knob (G) by spinning it clockwise. *See Figure 2A.*
4. Pull the knob downward and raise the clamp arm (F) to the upright position. *See Figure 2B.*
5. Release the securing knob and re-tighten it fully by turning it counterclockwise. *See Figure 2C.*
6. Open the height adjustment QR lever (C), raise the sliding tube (B) to a suitable height and close the QR lever. *See Figure 3.*

Note: To adjust QR lever clamping tension (if necessary) tighten or loosen the 5mm hex bolts on each QR lever. *See Figure 4.*

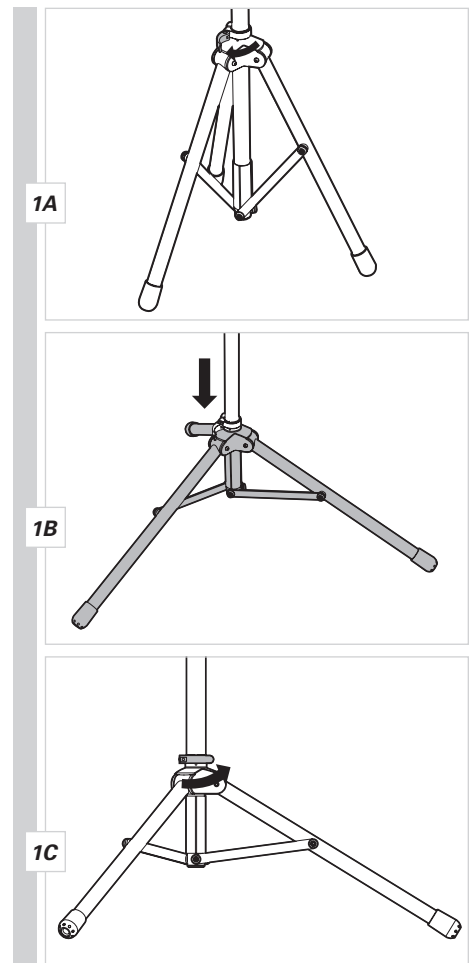

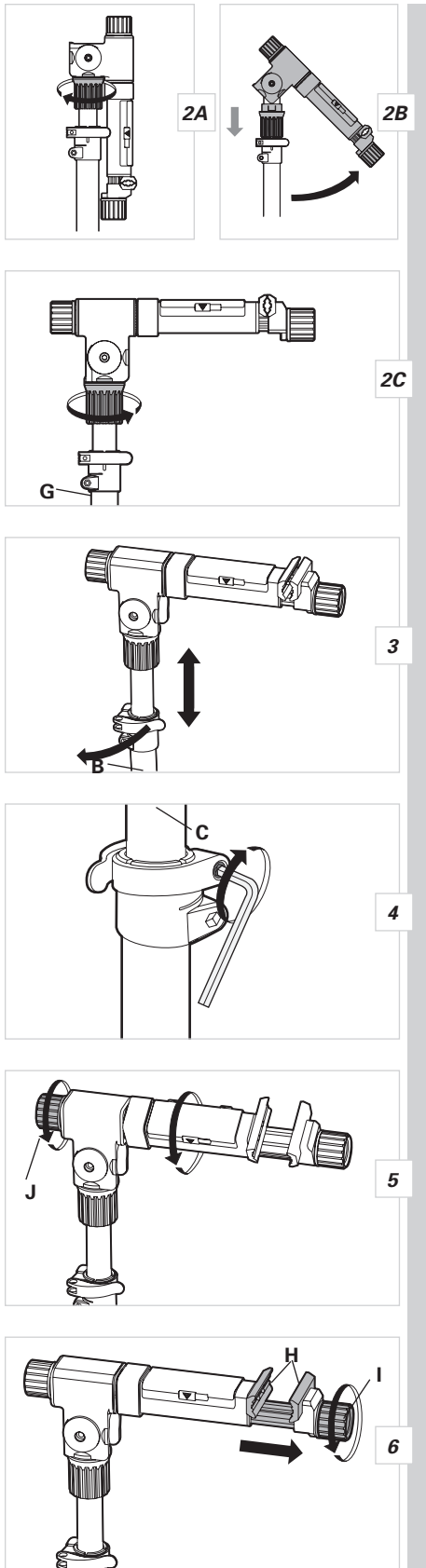

III. Using the Workstand

1. Set the PRO G3 Repair Stand on a flat, stable surface.
2. Raise or lower the sliding tube (B) to the desired height by opening the height adjustment QR lever, (C), adjusting the tube height and closing the QR lever. *See Figure 3.* The Air Cushion technology in the main tube allows stand height to be adjusted with or without a bicycle in the repair stand.
3. To rotate the clamp arm (F), loosen the clamp rotation knob (J), rotate the clamp arm to the desired position, and re-tighten the rotation knob securely. *See Figure 5.* This adjustment can be made with or without a bicycle in the stand. **Note:** Make sure the small parts box (K) is securely closed before rotating the clamp arm.
4. Open the clamp jaws (H) by spinning the clamp adjustment knob (I) counter-clockwise. *See Figure 6.*
5. Place your bicycle in the clamp jaws (H) and tighten the clamp adjustment knob until the bicycle is securely clamped in the stand. **Note:** To avoid possible frame damage, it is always best to clamp the bicycle by the seatpost rather than the frame itself. If you must clamp the frame, use minimal clamp pressure to avoid damaging the frame.

Tech Support 1(800)553-8324