

Magenta Keylines do not print



Pantone 2935
@ 70%



Pantone 2935
@ 100%

Tire Inflation

The Hurricane HPV dual Mini Pump offers two inflation modes. Use the high volume mode (Hv) for quick inflation of MTB tires and for initial inflation of road tires. Use the high pressure mode (Hp) to inflate road tires to full pressure.

1. Remove dust cap from tire valve. For Presta valves, unscrew metal locking barrel at tip of valve.
2. Depress tip of either type valve to ensure valve doesn't stick and to blow out any dirt or contaminants that may have settled there.
3. Open pump handle (A) and turn piston shaft (B) two "clicks" clockwise until "Hv" is aligned with one of the red arrows at end of pump barrel. See Figure 1. This is high volume mode.
4. Press the dual Presta/Schrader pump head (C) onto tire valve stem as far as it will go, and lift locking lever (D) to "locked" position as shown in Figure 2.
5. Inflate tire to desired pressure. When inflation becomes difficult, close pump and turn piston shaft two "clicks" counterclockwise until "Hp" is aligned with both red arrows at end of pump barrel. See Figure 3. This is high pressure mode.
6. Do not inflate tire beyond maximum recommended inflation pressure listed on tire sidewall. Once desired tire pressure is reached, release locking lever and remove pump head from valve stem.
7. For Presta valves, screw down locking barrel at valve tip. Replace valve stem dust cap.
8. To lock pump for storage or transport, turn piston shaft two "clicks" counterclockwise until "Hp" is aligned with both red arrows at end of pump barrel and then close handle.

Bracket Installation

1. Attach bracket (E) to frame using water bottle cage braze-on bolts. (See Figure 4.) Press pump into bracket until it snaps securely in place.

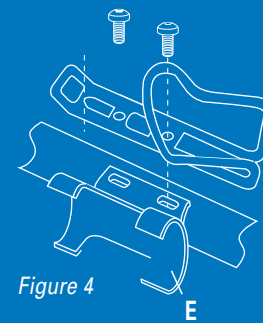
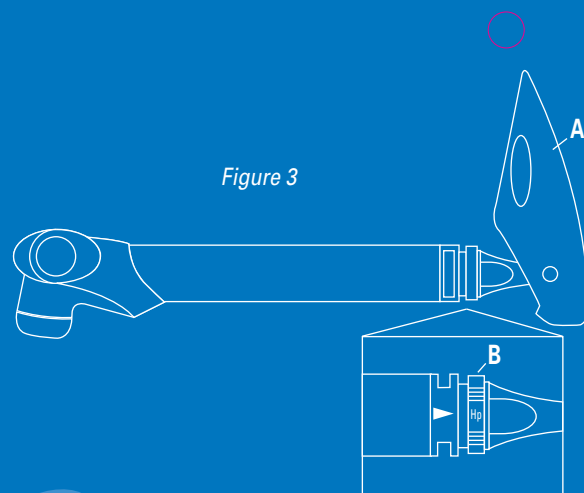
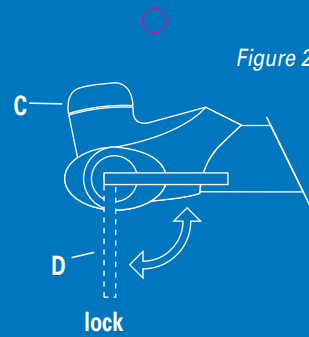
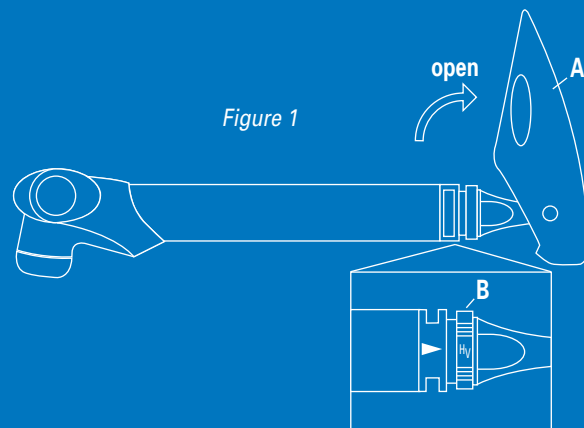

Tech Support Line 1-800-553-8324



Performance Inc.
One Performance Way
Chapel Hill, NC 27514
Made in Taiwan
PerformanceBike.com

PERFORMANCE and the Flying P are registered marks of Performance Inc.

40-2301 0405_1



Hurricane
HPV dual Mini Pump