

PERFORMANCE[®]

Performance Tech Support 1(800)553-8324



Performance, Inc.
One Performance Way
Chapel Hill, N.C. 27514
1-800-727-2453
Made in China
www.performancebike.com

PERFORMANCE and the Flying P Logo
are registered marks of Performance, Inc.

This product is
protected by
US Patent
5,792,030

40-2320 0705_1

PERFORMANCE®

Travel Trac

Millennium V

FLUID
FORCE
WIRELESS

fluid trainer with wireless computerized display



Thank you for your purchase of a Travel Trac™ trainer. Your new trainer provides the same data on speed, distance and time that is available from a full-featured cycling computer, plus information on power output (expressed in watts), elevation gain and slope (percent grade). Your indoor training has never been as fun or effective as it will be with your new Fluid Force Wireless Trainer!

NOTE: This trainer is intended for single-rider bicycles only.

⚠ CAUTION

- Read and follow all instructions.
- Before beginning each workout, be sure bicycle is securely attached to trainer.
- Portions of resistance unit can become hot during use. Do not touch resistance unit during or immediately after use.
- Keep children and pets away from trainer during use.
- Do not leave trainer unattended with spring plate in locked position.
- Before you start any exercise program you should consult a physician.

Table of Contents

I. About Your Fluid Force Trainer	2
II. Parts List	3
III. Assembly	3
IV. Bicycle Installation	3
V. Set-Up	4
VI. Using Your Fluid Force Trainer	4
A. Screens	5
B. Battery Life Indicator	6
C. Reset	5
D. Auto Off	6
E. Summary List of Ride Data	6
VII. Troubleshooting	6
VIII. Changing the Batteries	6
IX. Bicycle Removal	7
X. Travel and Storage	7
XI. Specifications	7

I. About Your Trainer

The Millennium V™ Fluid Force Wireless provides a fun, effective workout, and can easily be switched from bike to bike or between riders. Customize your workout as desired, and get the feedback you need to create a great training program!

MillenniumV™ Trainer Base

The Fluid Force resistance unit is mounted to a trainer base constructed of heavy-gauge powder-coated steel with shock-absorbing feet to provide a stable platform for any level of training. It is one of the most stable trainer bases available, but still folds compactly for storage or transport.

Fluid Resistance Unit

The Fluid Force resistance unit is equipped with an integrated sensor and wireless transmitter to send data to the handlebar mounted computer console. The fluid resistance unit provides continuously variable progressive resistance, characterized by smooth, quiet operation.

DuroTread Polyurethane Drive Roller

The unique DuroTread drive roller on the Fluid Force is made of durable polyurethane, which significantly reduces tire noise and tire wear while increasing traction between the tire and roller (less tire slippage). There are a few important points to keep in mind about the DuroTread roller:

1. To avoid damaging the roller, DO NOT apply the rear brake while using the trainer. Locking the rear wheel at high speed can seriously damage the polyurethane roller.
2. Allowing the tire to slip against the roller will also accelerate roller wear. If you notice the tire slipping regularly during use, you should:
 - A) Try to apply power more evenly when accelerating, and pedal with a smoother stroke.
 - B) Attach the resistance unit to the spring plate through the lower set of mounting slots. Loosen the 2 M5 bolts (D), position the resistance unit in the lower set of slots and retighten the bolts.
3. Use a smooth tread tire at least 23mm in width.
4. Maintain the recommended maximum inflation pressure for your tire.
5. Over time the DuroTread roller may show some slight signs of wear. This is normal, and does not affect the performance of the roller.

Computer Console

The computer console calculates and displays data provided by the resistance unit sensor. The large LCD screen mounts directly to the handlebar, and presents the data in an easy to read format.

Functions

The Fluid Force trainer provides the following valuable training feedback:

Speed: Current, Average, Maximum

Distance: Trip Distance, Total Distance (Odometer)

Time: Ride Time, Total Time

Power (Watts): Current, Average, Maximum

Slope (% Grade): Current, Average (Slope is simulated by the level of resistance. Please note that at any given resistance level Slope will vary according to rider weight.)

Elevation Gain: Total Elevation Gain, based on Trip Distance and Slope

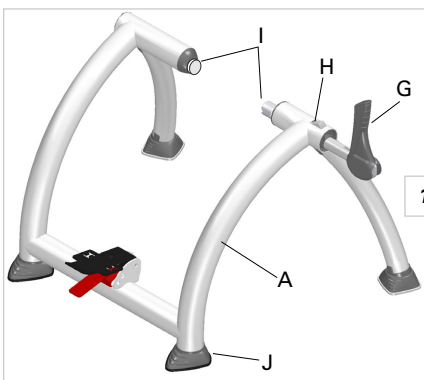

II. Parts List

Part	Part Code	Quantity
Trainer Base	A	1
Fluid Force Resistance Unit	B	1
Resistance Unit Spring Plate	C	1
Pivot Bolt, Washer, Nut	D	1 each
Computer Console	E	1
Rubber Shims for Console	F	2
Handle	G	1
Release Button	H	1
Axle Support Cups	I	2
Rubber Feet	J	4
M5 Bolts and Washers	K	2 each
"AA" Alkaline Batteries	(not shown)	2
Quick Release (QR) Skewer	(not shown)	1
5mm Hex Wrench	(not shown)	1

III. Assembly

1. Remove the trainer, resistance unit and all parts from the box. If you believe parts are missing, please contact our Technical Support department for assistance at 1-800-553-8324.
2. Attach the two rear rubber feet (J) to the trainer base (A) by pressing them into the ends of the trainer base frame tubes. See Figure 1.
3. Install the transmitter batteries in the resistance unit. Remove the screws and open the cover on the underside of the resistance unit. See Figure 2. Insert the two included "AA" batteries according to the diagram on the battery compartment cover, and replace the cover.
4. Use the included 5mm hex wrench and a 13mm box wrench or adjustable wrench to remove the pivot bolt, washer and nut (D) from the U-bracket on the trainer base (A). See Figure 3A.
5. Attach the spring plate (C) to the U-bracket as shown in Figure 3A. For proper functioning, insert the spring plate vertically in the U-bracket and insert the pivot bolt through the top set of holes in the U-bracket.
6. The protruding prong of the spring must be placed inside the bent tab on the U-bracket. See Figure 3B. Tighten the pivot bolt, washer and nut to a friction fit enough that the spring plate can pivot with some resistance.
7. Attach the resistance unit (B) to the spring plate using 2 M5 bolts and washers (K) as shown in Figure 3C. There are two sets of mounting slots in the spring plate. Attach the resistance unit to the spring plate using the upper set of mounting slots.

IV. Bicycle Installation

WARNING

Read and follow all instructions concerning installation of the bicycle on the trainer. Failure to securely attach the bicycle to the trainer could result in the bicycle falling, causing injury to the rider or bystanders.

1. Set the trainer on a flat, stable surface.
2. Replace the bicycle's rear wheel quick release (QR) skewer with the one provided with the trainer. See bicycle owner's manual for instructions on how to properly adjust the QR skewer. Make sure the QR skewer is tight and not damaged or bent.
3. Raise the handle (G) to the fully opened position. See Figure 4A. Depress the release button (H) and pull the handle away from the trainer frame to slide the axle support cup (I) all the way to the right.
4. Push the spring plate (C) down as far as possible towards the floor to engage the spring plate lock. See Figure 5. The spring plate must be locked down to install the bicycle.

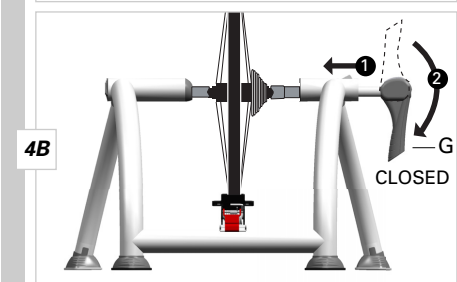
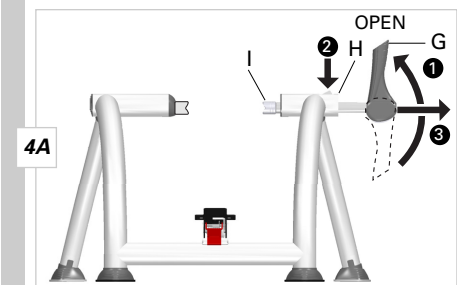
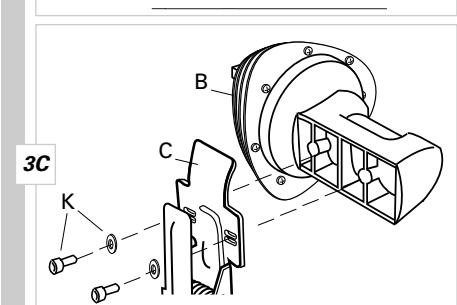
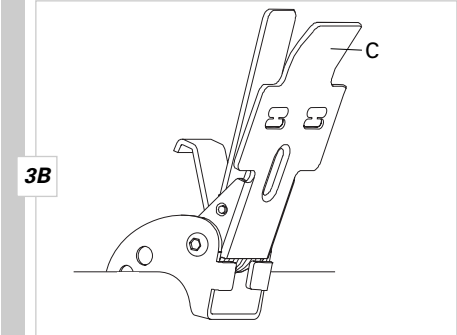
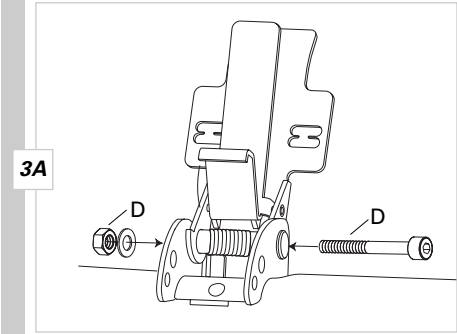
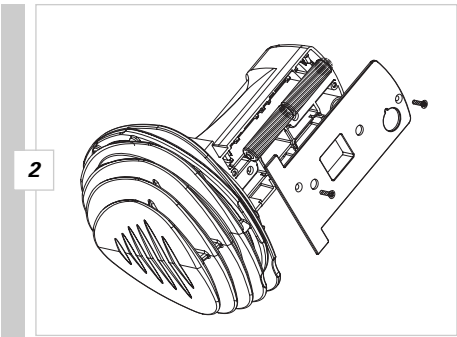

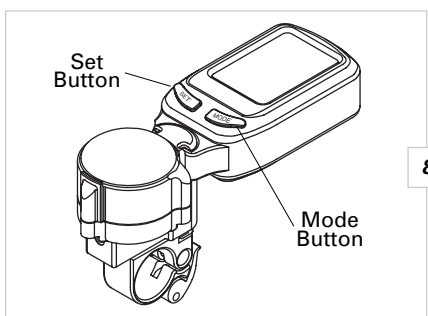
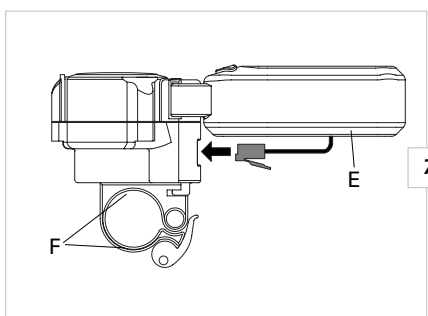
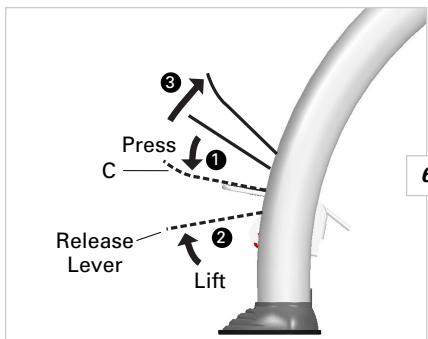
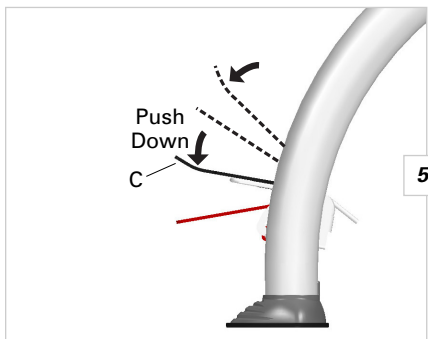

CAUTION

Do not leave trainer unattended with spring plate mechanism in locked (down) position. If accidentally released, it can spring forward with considerable force, causing possible damage or injury.

- Lift the bicycle into position, and fit the QR skewer lever on the left side of the wheel into the left axle support cup. Rotate the support cup as necessary, until the notch in the cup is aligned with the QR skewer lever.
- Push the handle (G) toward the trainer frame to slide the right side axle support cup against the QR skewer nut on the right side of the wheel. See Figure 4B. Once contact is made, rotate the handle all the way to the fully closed position to firmly clamp the QR skewer between both axle support cups.
- Check that the bicycle is securely installed in the trainer by pushing or pulling on the bicycle's top tube or seat.
- If the bicycle is not secure, check to see that the QR skewer lever and nut are properly positioned in the axle support cups, and that the handle is fully closed.

WARNING

Failure to securely attach the bicycle to the trainer could result in serious injury.

- Release the spring plate (C) by pushing down on the top of the spring plate with the palm of your hand, and then pulling up on the spring plate release lever with your fingers. Carefully allow the spring plate to rotate upwards until the resistance unit roller makes contact with the bicycle's rear tire. See Figure 6.
- Install the batteries in the computer console (E). Remove the battery cover from the underside of the console, install the batteries according to the orientation diagram inside the battery compartment, and replace the cover.
- Attach the computer console to the handlebar, preferably close to the stem. It may be necessary to remove one or both of the rubber shims (F) from the console bracket in order to fit larger diameter handlebars.
- Connect the computer console cable to the console body as shown in Figure 7.

Tip: To make your indoor workout as quiet as possible, set the trainer on a small section of carpet, and use a rear tire with a smooth tread pattern.

V. Setup

Data generated by the Fluid Force Wireless computer will be accurate only if you first perform the following simple set-up procedure. The set-up screens cannot be accessed while the trainer is in use.

Note: In order to provide accurate data, the weight setting (rider weight + bicycle weight) must be programmed for each user. When switching riders, be sure to program the weight setting (see below).

- To enter the set-up screens, press and hold the right (MODE) button for 4 seconds. See Figure 8.
- Select metric or imperial units of measure. Press the left (SET) button to select between KM/H, Meters and Kilos, or M/H, Feet and Pounds (Lb). See Figure 9. Press the MODE button to confirm your selection and proceed to the Weight set-up screen.
- The weight value will appear on the top line of the display screen, with the right digit flashing. See Figure 10. **Note:** This value represents the combined weight of the rider and the bicycle. Enter the combined weight of the rider and bicycle by pressing the SET button to adjust the flashing digit. Press the MODE button to enter your setting and proceed to the next digit. Repeat this process to set the remaining digits. When finished, press the MODE button to confirm the value and proceed to the Type set-up screen.
- The correct Type setting for the Travel Trac™ Fluid Force is Type 3. See Figure 11. Press the SET button until "type 3" is displayed. Press the MODE button to confirm your selection and exit the set-up screens.

VI. Using Your Fluid Force Wireless Trainer

Once the bicycle is mounted to the trainer (see section IV), and the initial set-up is complete (see section V), you are ready to ride.

1. Release the spring plate (C) by pushing down on the top of the spring plate with the palm of your hand, and then pulling up on the spring plate release lever with your fingers. Carefully allow the spring plate to rotate upwards until the resistance unit roller makes contact with the bicycle's rear tire. See Figure 6.
2. Press either button (SET or MODE) or begin pedaling to activate the computer. Current Speed and other data should immediately appear in the display screen.

Note: The Slope and Power readings will vary from rider to rider according to the weight value entered in the set-up process (see section V). Therefore, the Slope and Power readings may differ for two riders riding at the same speed and same resistance level settings. The indicated Slope value for each resistance setting is calculated based on the combined rider and bicycle weight.

Note: For accurate Slope, Power and Elevation Gain data, remember to reset the weight value (see section V) when switching between riders.

A. Screens

Three display screens provide various training data as described below. Use the MODE button to scroll between the three screens. All screens can be viewed during a ride.

Screen 1 (Figure 12)

Displays current values for Power (watts), Speed, Slope, Trip Distance and Ride Time. The ▲▼ speed comparison arrows in the upper right corner of the screen compare current speed to average speed. An upward arrow indicates your current speed is above your average speed. A downward arrow indicates your current speed is below your average speed.

- A. Current Power
- B. Current Speed
- C. Slope
- D. Trip Distance
- E. Ride Time
- F. Speed Comparison

Screen 2 (Figure 13)

Displays average values for Power (watts), Speed and Slope. Also displayed are Trip Distance, Ride Time and Speed Comparison arrows.

- A. Average Power
- B. Average Speed
- C. Average Slope
- D. Trip Distance
- E. Ride Time
- F. Speed Comparison

Screen 3 (Figure 14)

Displays maximum values for Power (watts) and Speed, Elevation Gain, Total Distance (odometer) and Total Ride Time. Also displayed are the Speed Comparison arrows. The Total Distance and Total Ride Time values represent total distance and time accumulated on all rides to date, and will not be reset when the data screens are cleared (see Section C, "Reset").

- A. Maximum Power
- B. Maximum Speed
- C. Elevation Gain
- D. Total Distance
- E. Total Ride Time
- F. Speed Comparison

B. Battery Life Indicator

When battery life is low, a battery icon will flash in the display screen to indicate only a few hours of battery life remain. See Figure 15. When the battery icon appears, replace the batteries as soon as possible.

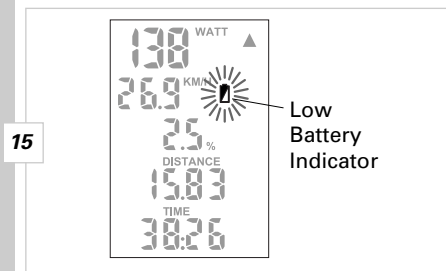
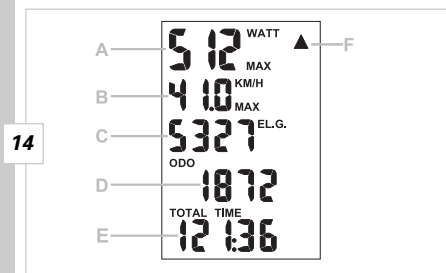
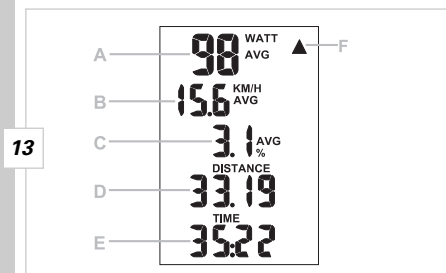
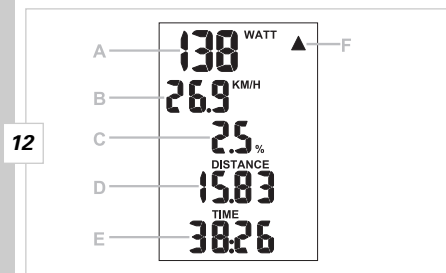
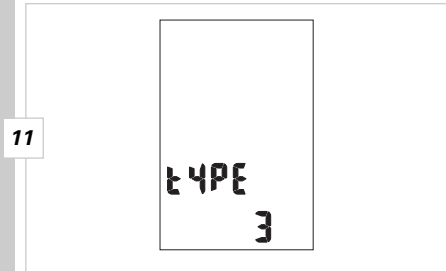
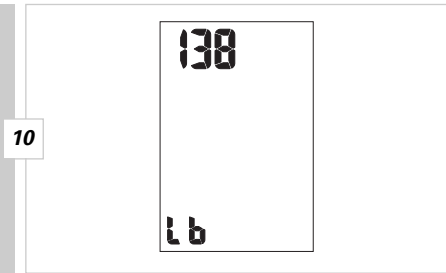

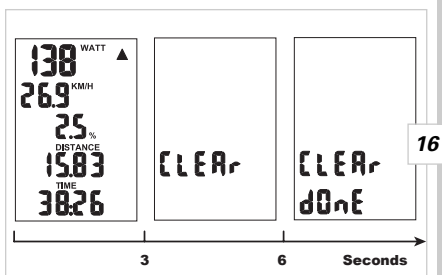

C. Reset

At the beginning of each ride you'll want to perform a reset to clear from memory the data from your previous ride.

1. To clear the data, press and hold the SET button. After 3 seconds, "CLEAR" will be displayed (at this point no data has been deleted). Continue to hold the SET button and in another 3 seconds "DONE" will appear, indicating that all accumulated data (except Total Distance and Total Ride Time) has been cleared from memory. See Figure 16.
2. To reset Total Distance and Total Ride Time (as well as all other data), press and hold both the SET and MODE buttons. After 8 seconds "CLEAR" will be displayed (at this point no data has been deleted). Continue to hold the SET and MODE buttons, and in another 2 seconds "DONE" will appear, indicating that all accumulated data has been cleared from memory.

D. Auto Off

After 2 minutes of inactivity (no pedaling or button presses) the system will automatically switch off to prolong battery life. Current values will be maintained. To turn the system back on press either button (SET or MODE) or begin pedaling.

E. Summary List of Ride Data

SYMBOL	SCREEN	INFO
WATT	1	Current Power
KM/H- M/H	1	Current Speed
%	1	Slope (% Grade): A function of the resistance level and the rider + bike weight
DST	1-2	Trip Distance: Distance accumulated during current ride (or since last reset)
TIME	1-2	Ride Time: Time accumulated during current ride (or since last reset)
▲▼	1-2-3	Speed Comparison: Indicates whether current speed is above or below average speed
AVG WATT	2	Average Power developed for current ride (or since last reset)
AVG KM/H-M/H	2	Average Speed for current ride (or since last reset)
% AVG	2	Average Slope for current ride (or since last reset)
MAX WATT	3	Maximum Power: Indicates maximum wattage attained during current ride (or since last reset)
MAX KM/H	3	Maximum Speed: Indicates highest speed attained during current ride (or since last reset)
ELV.G	3	Elevation Gain: Indicates total elevation climbed during current ride (or since last reset)
ODO	3	Total Distance: Indicates total distance accumulated on all rides to date.
TOTAL TIME	3	Total Ride Time: Indicates total ride time accumulated on all rides to date.
⚡	1-2-3	Low Battery Indicator: Indicates batteries should be replaced

VII. Troubleshooting

1. **Display not working**
 - a. Check cable connection to the computer console.
 - b. Replace the batteries in the computer console and/or resistance unit. See section VIII, "Changing the Batteries."
2. **Data Values Erratic**
 - a. Check cable connection to the computer console.
 - b. Replace the batteries in the computer console and/or resistance unit. See section VIII, "Changing the Batteries."
3. **Low Battery Indicator Appears**
 - a. Replace the batteries in the computer console and/or resistance unit. See section VIII, "Changing the Batteries."

VIII. Changing the Batteries

The computer console and resistance unit transmitter each use 2 "AA" batteries. When the low battery life indicator appears in the display, or if the display is erratic, faint or disappears altogether, new batteries are needed.

Console

1. To replace the console batteries, remove the battery cover from the underside of the computer console.
2. Remove the used batteries and dispose of properly.

3. Install fresh batteries according to the diagram inside the battery compartment, and replace the cover.

Transmitter

1. To replace the transmitter batteries, remove the screws and open the cover on the underside of the resistance unit. See Figure 2A.
2. Remove the used batteries and dispose of properly.
3. Install fresh batteries according to the diagram on the battery compartment cover, and replace the cover.

Note: During a battery change, current data and set-up values will be retained in memory.

IX. Bicycle Removal

1. Push the spring plate (C) down as far as possible towards the floor to engage the spring plate lock. See Figure 5. The spring plate must be locked down to remove the bicycle.
2. Raise the handle (G) to the fully opened position. See Figure 4A. Depress the release button (H) and, while supporting the bicycle, pull the handle away from the trainer frame to slide the axle support cup (I) all the way to the right until the rear wheel axle is free of the support cups.
3. Release the spring plate by pushing down on the top of the spring plate with the palm of your hand, and then pulling up on the spring plate release lever with your fingers. Carefully allow the spring plate to rotate all the way forward. See Figure 6.
4. The QR skewer provided with the trainer can be used when riding the bicycle off the trainer as well. If you choose to reinstall your bicycle's original skewer, refer to your bicycle owner's manual for instructions on properly adjusting the skewer. Before riding, ensure the quick release skewer is tight.

CAUTION

Do not leave trainer unattended with spring plate mechanism in locked (down) position. If accidentally released, it can spring forward with considerable force, causing possible damage or injury.

X. Travel and Storage

1. Release the spring plate (C) by pushing down on the top of the spring plate with the palm of your hand, and then pulling up on the spring plate release lever with your fingers. Carefully allow the spring plate to rotate all the way forward. See Figure 6.
2. Fold the legs together, and the trainer is ready for transport or storage. Be careful when folding the legs to avoid pinching your fingers.

XI. Specifications

Battery Type: 4 "AA" Alkaline Cells

Battery Life: Approximately 300 hours

Computer Data Fields:

Power (watts): up to 999 watts

Speed: up to 99.9 miles/hour or 99.9 kilometers/hour

Distance: up to 999.99 miles or kilometers

Odometer: up to 99999 miles or kilometers

Ride Time: up to 9 hours, 99 minutes, 59 seconds

Total Time: up to 999 hours, 59 minutes

Elevation Gain: up to 9999 feet or meters

Weight Input Field: up to 330 pounds or 150 kilograms

Units of Measurement:

Metric: Distance in Kilometers, Elevation in Meters, Weight in Kilograms, Speed in Kilometers/Hour

Imperial: Distance in Miles, Elevation in Feet, Weight in Pounds, Speed in Miles/Hour