

Performance Inc.

One Performance Way
Chapel Hill, NC 27514

Made in Taiwan

PerformanceBike.com

PERFORMANCE and the Flying P logo are registered trademarks of Performance, Inc.

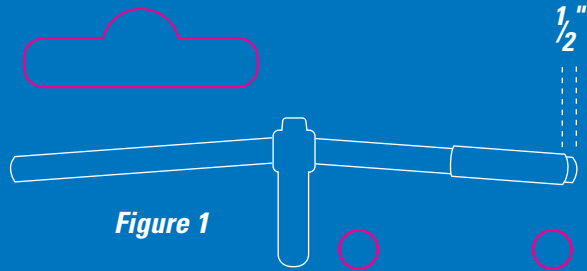

Figure 1

Installation:

1. Expose half an inch of each end of the handlebar either by moving the grips inward or by cutting off the ends of the grips (see fig. 1).
2. Install your Bar Ends on the ends of your handlebar with the clamps facing down and the extensions facing forward and angling inward. An angle of 10° to 30° from horizontal is recommended as a good initial setting, but each rider should adjust according to personal preference (see fig. 2).
3. Cap the ends of your handlebar with the provided plugs.

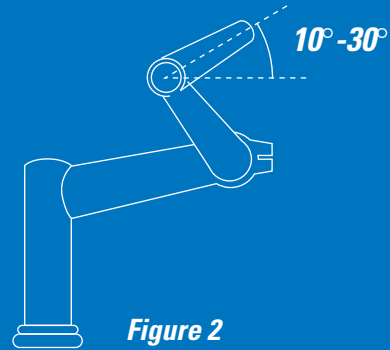

Figure 2

Tech Support Line
1-800-553-8324

50-1735



Forté
Pro Stix

KEYLINES DO NOT PRINT!

PMS 2935 

BLACK 

WHITE 