

PERFORMANCE[®]

Forté TEAM MTB Brakes

Congratulations on your purchase of Forté Team MTB Brakes. To install and adjust your brakes you will need:

- 5mm hex wrench
- 2mm hex wrench

⚠ WARNING

Proper brake operation is critical to your safety. Brakes or Brake Levers that are improperly installed or adjusted could lead to an accident resulting in serious injury or death. To ensure that you have installed these components correctly, consult a qualified bicycle mechanic.

Instructions

1. Forté Team MTB Brakes must be used with levers designed for linear (direct) pull brakes.
2. Forté Team MTB Brakes come in pairs. A pair is needed for each wheel. They are sold specifically for front or rear wheels. Be sure to use the appropriate set for the given application (see figure 1).
3. To determine if the brake is for front or rear, check that the direction arrows on the shoes are pointed towards the front of the bicycle.
4. Right and left brake shoes are identified by an "R" and "L". Right and Left are from the perspective of a rider on the bicycle.
5. New cables and housing are almost always needed when new brakes are installed.

Installation

1. Remove existing brakes.
2. **IMPORTANT:** Identify the new brakes. Confirm front or rear as per Note #3 above.
3. Slide one of the brake arms onto a lightly greased brake boss. Be sure that the pin on the back of the arm is seated in the spring hole on the brake boss (see figure 2). If there is more than one hole, choose the hole nearest the center of the brake boss.
4. Thread the brake fixing bolt (with washer) into the brake boss, and tighten the bolt to 43–61 inch/lbs of torque (see figure 2).
5. Repeat steps 3 and 4 to install the remaining brake arm. Install the wheel to be used if it is not already in place.
6. Adjust each brake shoe so that the brake pads are square with the rim when the brake is actuated. There should be a gap of approximately 1mm between the top of each pad and the top edge of the rim (see detail in figure 3).
7. Finger tighten the brake shoe nut to hold the parts in place.
8. Measure the distance between the guide tube holder and the cable fixing bolt. This should be at least 39mm with both pads touching the rim (see figure 4).
9. If the distance is less than 39 mm, reverse the position of the 3mm and 6mm brake shoe washers (see figure 5).
10. Tighten each brake shoe nut to 50–60 inch/lbs of torque.
11. Install the cable and housing. Thread the cable through the guide tube and install the guide tube in the guide tube holder. Thread the cable through the dust cover. Loosen the cable fixing bolt and slide the cable under the cable fixing bolt washer (see figure 4).
12. Leave enough slack in the housing to allow the brake to travel through its arc.
13. Tighten the cable fixing bolt to 50 inch/lbs of torque.
14. Squeeze the brake lever firmly about 10 times to seat the cable and housing.
15. Check that the leading edges of the brake pads are approximately 1mm from the rim. The pads should be parallel to the rim surface.
16. To center the brakes with 1mm clearance between each pad and the rim surface, adjust cable tension at the brake lever and spring tension at each brake arm. Use a 2mm hex wrench to tighten or loosen the tension adjustment screws. Tighten (clockwise) the bolt to move the pad away from the rim.

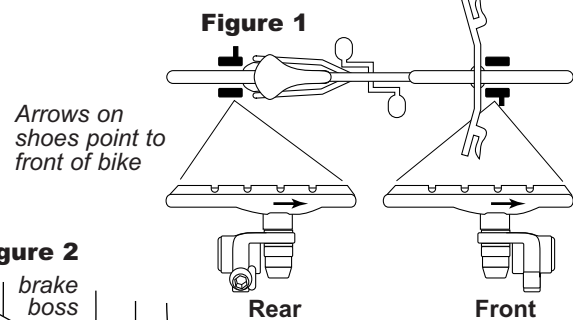

Figure 2

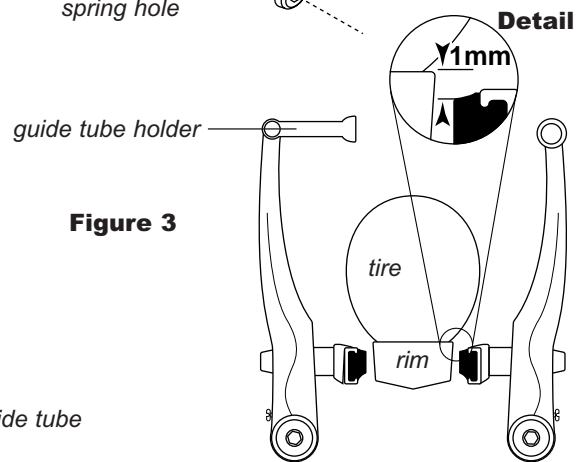
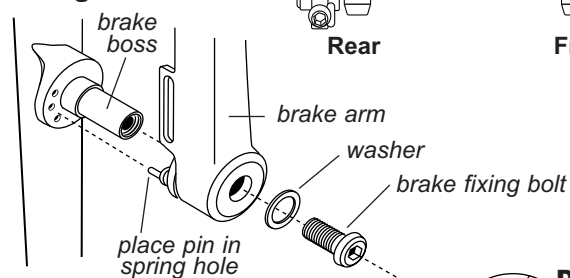

Figure 3

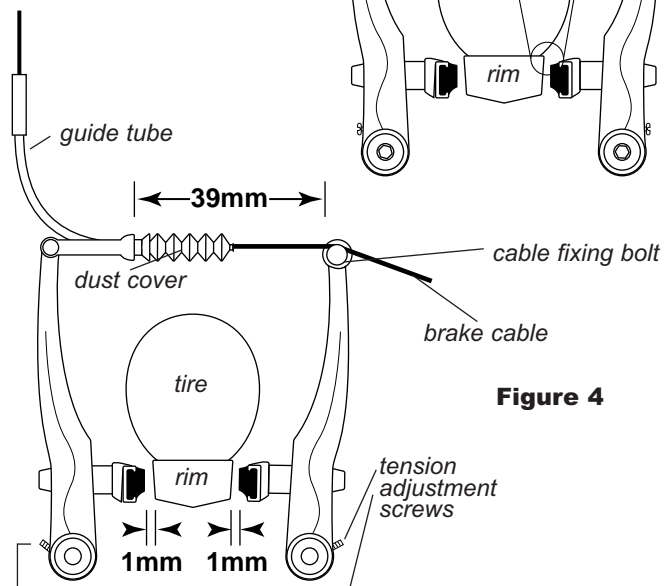

Figure 4

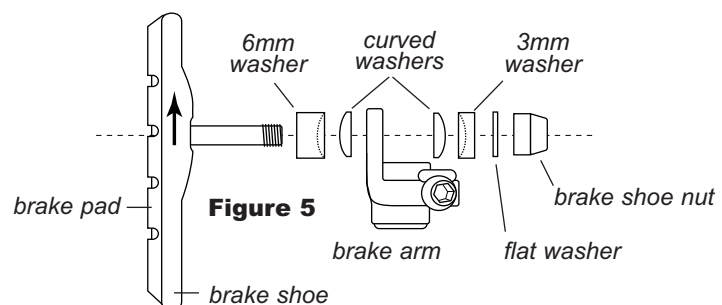

Figure 5



Performance, Inc.
One Performance Way
Chapel Hill, N.C. 27514
Made in Taiwan
www.performancebike.com

PERFORMANCE and the Flying P Logo are registered marks of Performance, Inc.

Performance Tech Support 1(800)727-2453
9am-6pm EST Monday-Friday