

PERFORMANCE®

TECHNIQUE

Folding Rollers

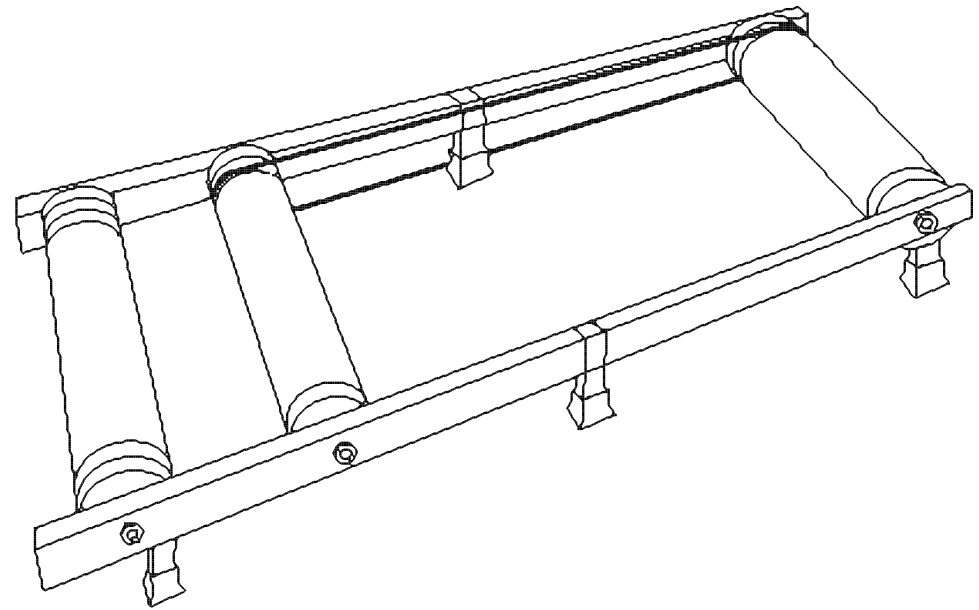

Performance Inc.
One Performance Way
Chapel Hill, NC 27514
www.performancebike.com
1-800-727-2453

Instructions For Adjustment and Use

TECHNIQUE

Folding Rollers

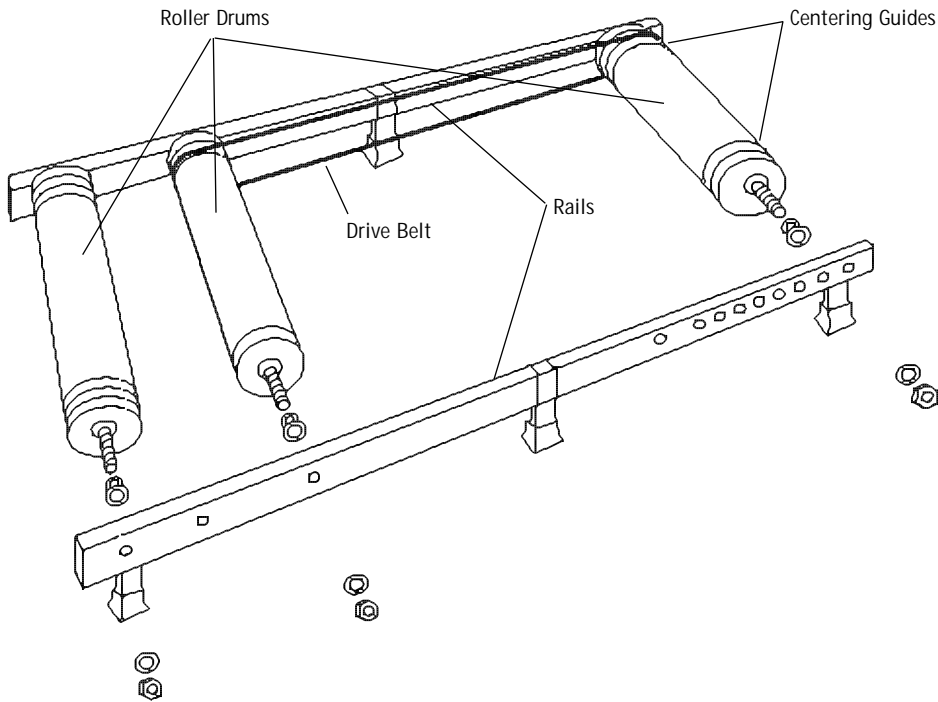
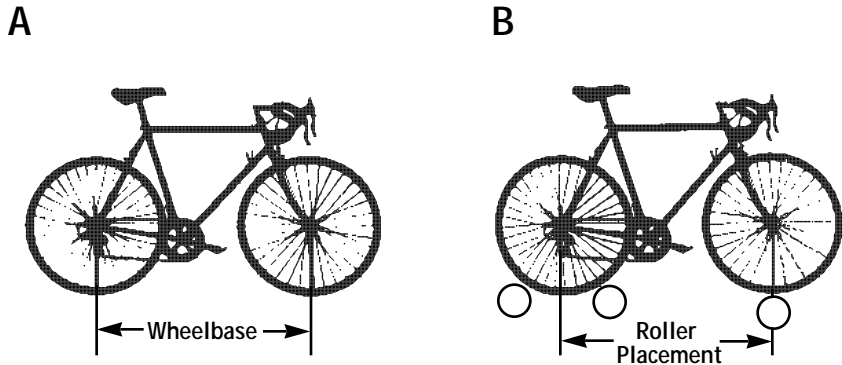

Note: Left and right are from rider's perspective.

1. The rollers are already assembled, and only need to be unfolded, making sure that the drive belt is in the grooves on the front and middle roller cylinders.
2. Measure the wheel base (diagram A) on the bicycle to be ridden. The distance from the centerpoint between the two rear roller cylinders to the center of the front cylinder is indicated on the sticker above the axle holes. Position the front cylinder in the pair of axle holes which most closely matches the measurement of your bicycle wheel base. **Do not position axle of front cylinder behind the front axle of your bike** (diagram B).
3. If it is necessary to move the front cylinder for proper adjustment, fold rollers to slacken tension on the drive belt. Disengage the belt completely from the front roller. Unfold rollers. Remove front cylinder axle nuts and washers from both sides. Loosen as necessary the nuts on the right side of the middle and rear cylinders, so the front cylinder can be completely removed. Move front cylinder to proper position as per step #2. Reattach all nuts and washers, but do not tighten. Fold rollers enough to place drive belt as described in step #1. Unfold rollers and tighten all axle nuts. Do not overtighten, as the rails could become deformed. The rollers are now ready for use.

Riding Tips

1. Rollers are best used with smooth tires. If you are using a mountain bike, switching to a slick tire decreases noise and increases stability.
2. Make sure you use rollers on a level surface.
3. If you are new to roller riding, set up rollers in a doorway or beside a stable object, to help lend support while you master the required balance. Generally you should be looking forward (as you would on the road) rather than looking down. This will help you ride in a "straight line." Looking at a fixed object directly in front of the center point of your rollers is recommended. Position this object 10-15 feet in front of you. If you find yourself looking down, be sure to utilize the centering guides that provide a margin of safety from the end of the drum.
4. Initially, the feeling is like riding on ice - move the handlebars too much and you may lose your balance. This is the great advantage of rollers over trainers - they teach you to reduce upper body movement to a minimum as well as to maintain a smooth pedaling style.
5. Maintaining a high-rpm pedal cadence is essential in helping you to be properly balanced on the rollers, due to the gyroscopic effect of fast-spinning wheels. We advise that your initial workouts be done with moderate gearing, until you feel comfortable riding the rollers.

For additional resistance, an accessory kit is available for your Technique rollers. The HF-300R Fluid Resistance Unit (item #00-2325) can be attached to increase the workload of your Technique rollers.

FOR FURTHER ASSISTANCE: Please call our Technical service department at 1-800-727-2453. (9am to 6pm EST)