

XPORT ROOF RACK SYSTEM XPress

kayak carrier

Thank you for choosing the XPORT XPRESS Kayak carrier. This carrier is designed to hold a whitewater or sea kayak. The XPORT XPRESS Kayak Carrier is made to mount easily and quickly on the XPORT XPRESS roof rack system.

These instructions assume that you already have an XPORT XPRESS roof rack (Hook Kit, Foot Pack and Crossbars) mounted to your vehicle. To properly install the roof rack, please see the instructions included with the XPRESS Crossbar.

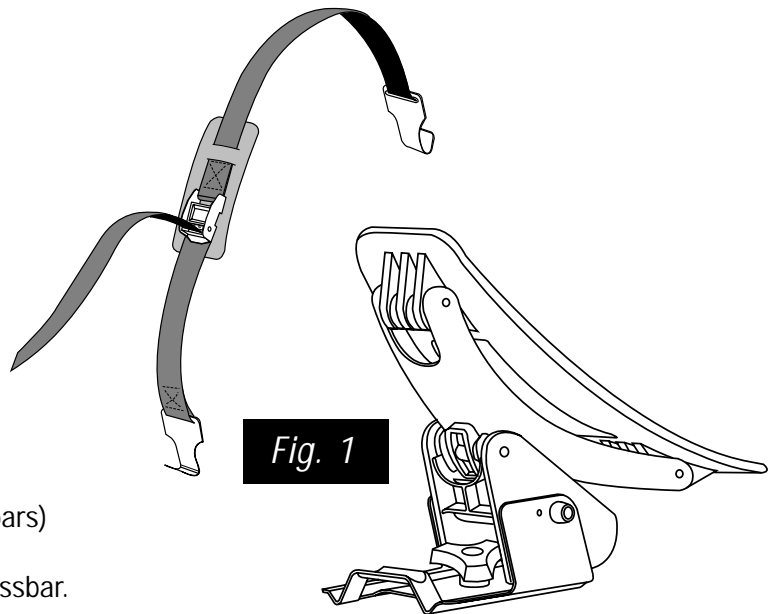

Fig. 1

Please read and understand the following roof rack guidelines:

⚠ WARNING: Pay particular attention to the vehicle manufacturer's roof weight bearing recommendation. For security and safety, you must refer to the vehicle manufacturer's guidelines for the permissible weight for a roof top carrier.

- Use only racks or accessories that are compatible with the XPORT XPress Roof Rack System, and only for vehicles listed in the XPORT XPress Fit Guide.
- Do not carry more than 165 lbs on the XPORT XPress Crossbars. Use of the XPORT XPress rack does not increase gutter or roof strength. Misuse can result in damage to vehicle, gear and rack. Other vehicles can be damaged and people can be hurt or killed in accidents caused by a rack falling from a vehicle.

⚠ CAUTION: It is the consumer's responsibility to ensure safe and proper installation.

- Read and follow the instructions carefully.
- Drive safely. Do not exceed the posted speed limit while using the rack.
- Please note that vehicles handle differently when a roof rack is fitted, and especially when loaded. Vehicles may corner and brake differently, and may be more vulnerable to side winds.
- It is essential that all connections and accessory attachments be tightened correctly and checked at regular intervals.
- For reasons of safety and fuel efficiency, removal of the rack is recommended when not in use.
- The rack may limit the operation of some sun roofs.
- Clean with mild soap and water only. Some chemicals can damage nylon and rubber parts.
- If the kayak extends beyond your rear bumper, it is recommended to attach a "red" warning flag on the trailing edge.

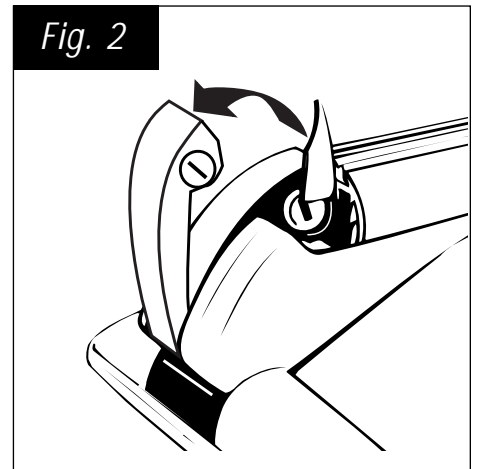

Fig. 2

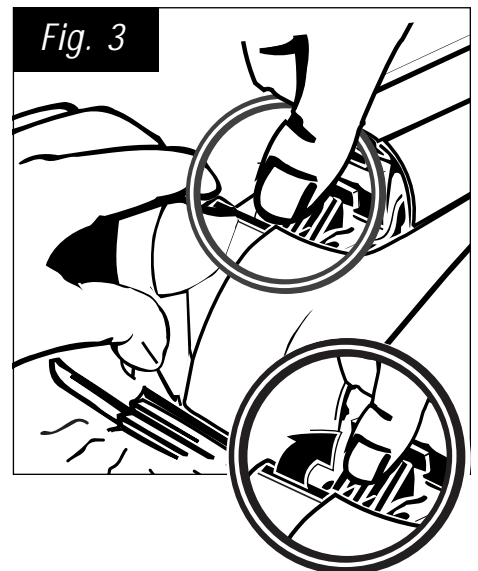

Fig. 3

Parts Included:

Qty	Part
4	Kayak Carrier Cradles
2	Web strap sets with 2 coated hooks
2	Web strap sets with 1 coated hook and a woven loop

Assembly & Installation:

If the Foot Assembly on your rack is already open, proceed to step 5.

1. Push the lock cover up to expose the keyhole (see figure 2).
2. Unlock the mechanism with your key. Pull the Black Lever back with out clicking the ratchet mechanism (see figure 3).
3. Push down on the yellow release button that is now exposed while holding a light tension on the black lever (figure 3).
4. Push the Black Lever closed creating slack (no tension) on the steel strap. The Black Lever can now be fully opened (figure 4).

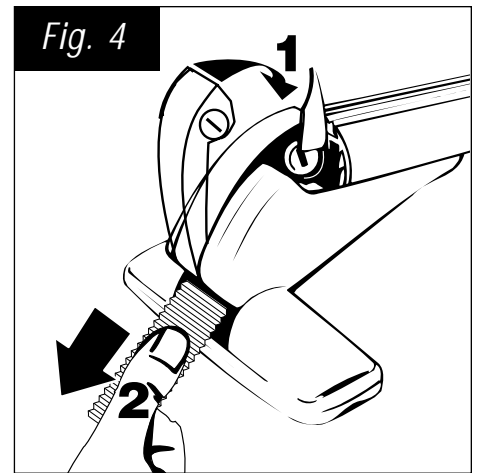

5. Remove the rubber trim strips from the top of the Foot Assemblies and/or Crossbars (depending on where on the rack the Kayak Carrier is to be mounted)

Note: The rubber trim pieces can be cut and replaced as needed.

6. Slide the steel plates of the Kayak Carrier Cradles into the channels at the top of the Foot Assemblies (figure 5).
7. Repeat for the other 3 cradles.
8. Once the cradles are placed in the desired position, tighten the black plastic knobs just enough to keep the cradles from sliding freely.
9. Place your boat on top of the vehicle. Slide the Kayak Carrier Cradles into their final position to best center and level the boat. Fully tighten the plastic knobs.

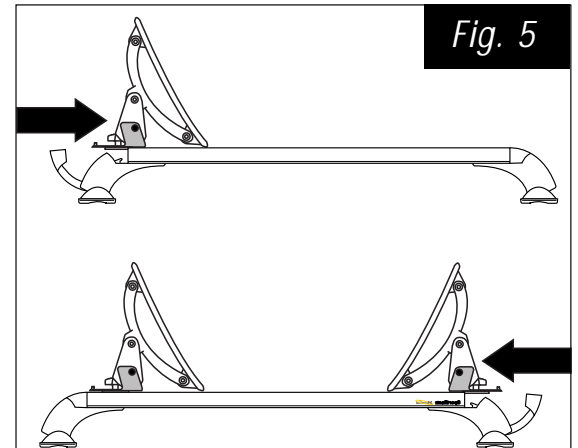

10. Slide a coated hook from one of the Web Strap Sets into the Hook fastener on a front Cradle (see figures 1 and 6). Carefully pass the opposite end of the Web Strap over the kayak to the other side.

Note: Use care to keep the web strap from twisting when it is attached to the opposite side of the kayak.

11. Hook the other side of the strap set into the opposite cradle as shown in figure 7.

Note: Be sure to tuck the protective flap (attached to the strap) under the metal buckle to protect your kayak's finish.

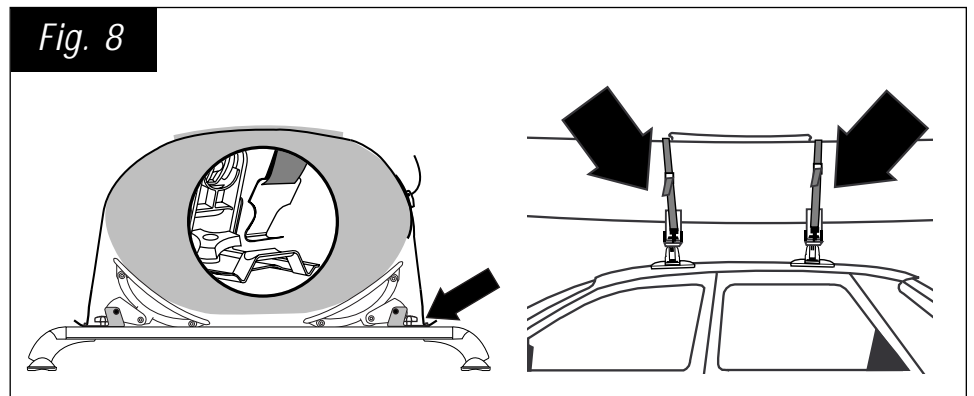
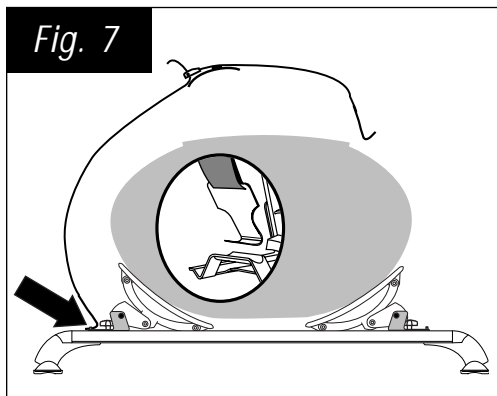
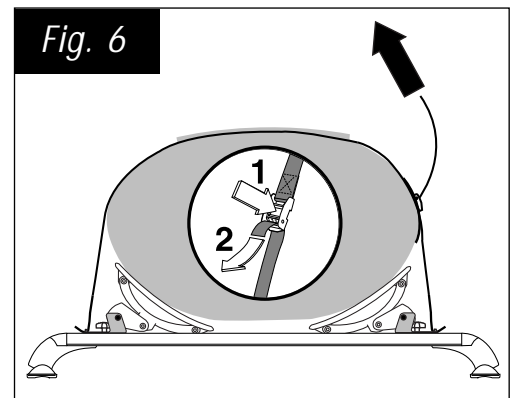

12. Repeat steps 10 and 11 for the rear Cradles. Pull up on the straps to tighten the kayak into place. See figure 8.

13. Make sure your kayak has not shifted in place when tightening the straps. If so, loosen the straps and readjust the kayak's position. Re-tighten the web straps

For additional security, the second set of web straps can be used to secure the bow and stern of your kayak.

14. Follow figure 9, steps A-E to attach the web security straps. Use care to only hook the coated hook to a metal attachment point.

CAUTION: Do not attach the coated hooks to fiberglass or plastic.

Note: To keep the straps from vibrating while driving, twist the straps 4-5 times as shown in figures 9D and 9E.

Fig. 9

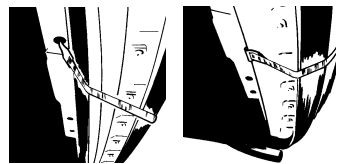
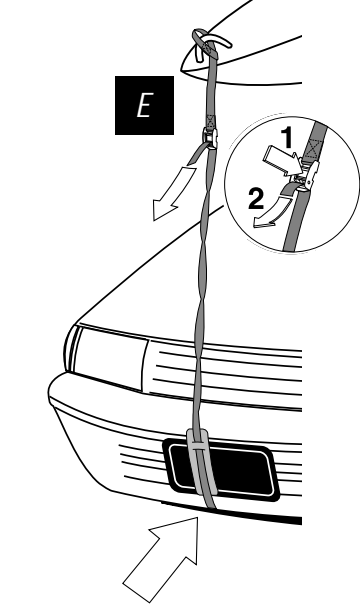
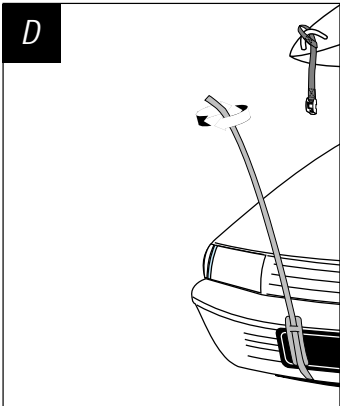
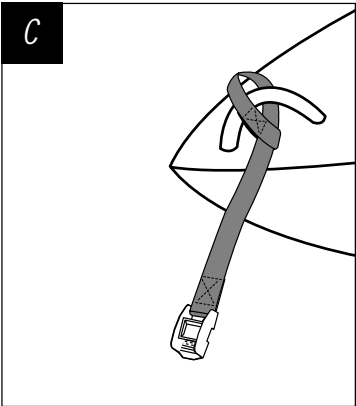
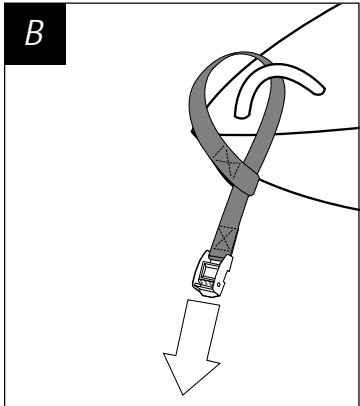
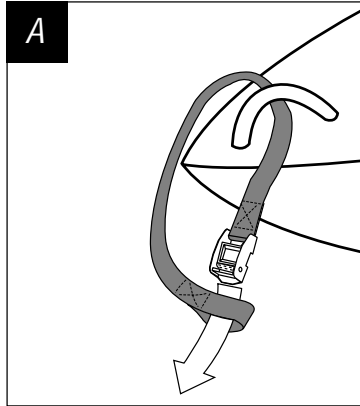
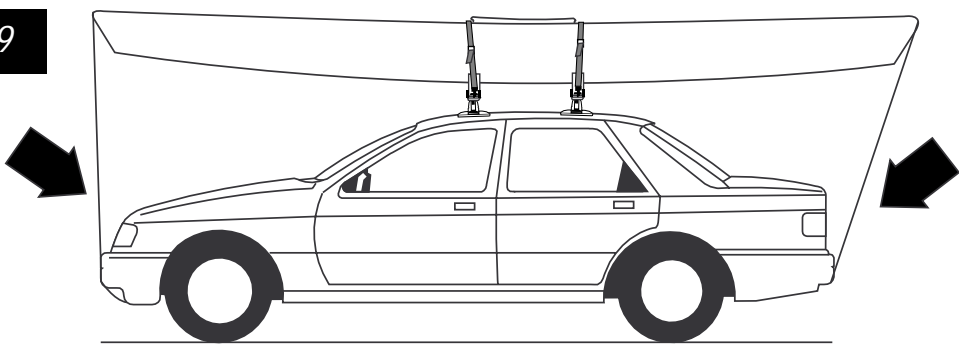

**Performance Tech Support 1(800)553-8324
9am-6pm EST Monday-Friday**



Performance, Inc.
One Performance Way
Chapel Hill, N.C. 27514
Made in Canada
PerformanceBike.com

PERFORMANCE and the Flying P Logo are registered marks of Performance Inc.